



# **The Role of CFD in Stores Certification**

**Dr Scott A. Morton  
USAF SEEK EAGLE Office  
Eglin AFB, Florida**

**High Performance Computing Users Forum  
April 14-16, 2008**

**DISTRIBUTION A. Approved for public release; distribution unlimited.**

# Air Force SEEK EAGLE Office

---

- Air Armament Center has two major components
  - Weapons System Program Offices
  - Test Wing including Flight Test and SEEK EAGLE Office
- USAF Aircraft-Store Certification Program (SEEK EAGLE Process)
  - Store loading procedures
  - Carriage loads\*
  - Store separation\*
  - Flutter\*
  - Ballistic accuracy
  - Stability & control\*
  - Safe escape
- Stores Include
  - Munitions, fuel tanks
  - Suspension equipment
  - Pods for navigating, sensing, targeting



# Air Force SEEK EAGLE Office Role

---

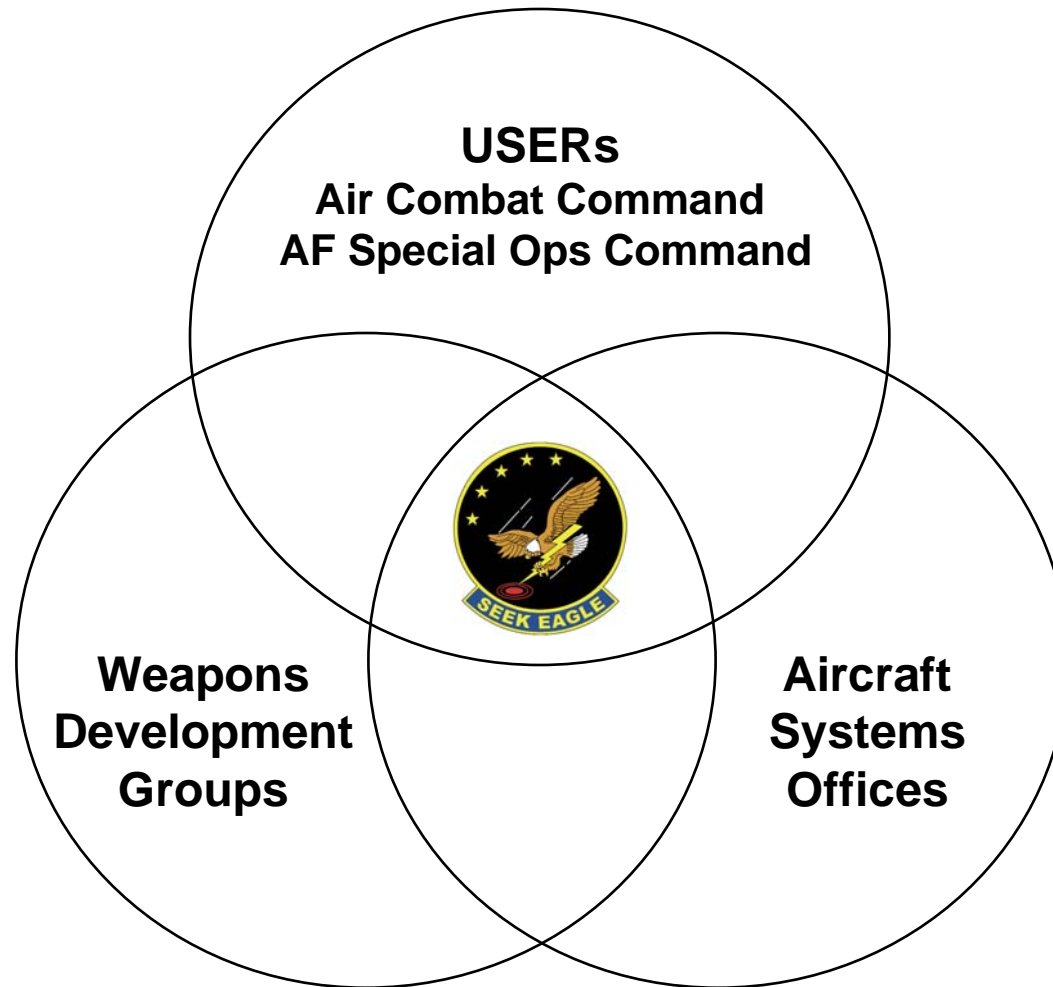

AFSEO is AF Store **test and EVALUATION**



# Aircraft Store Certification Process

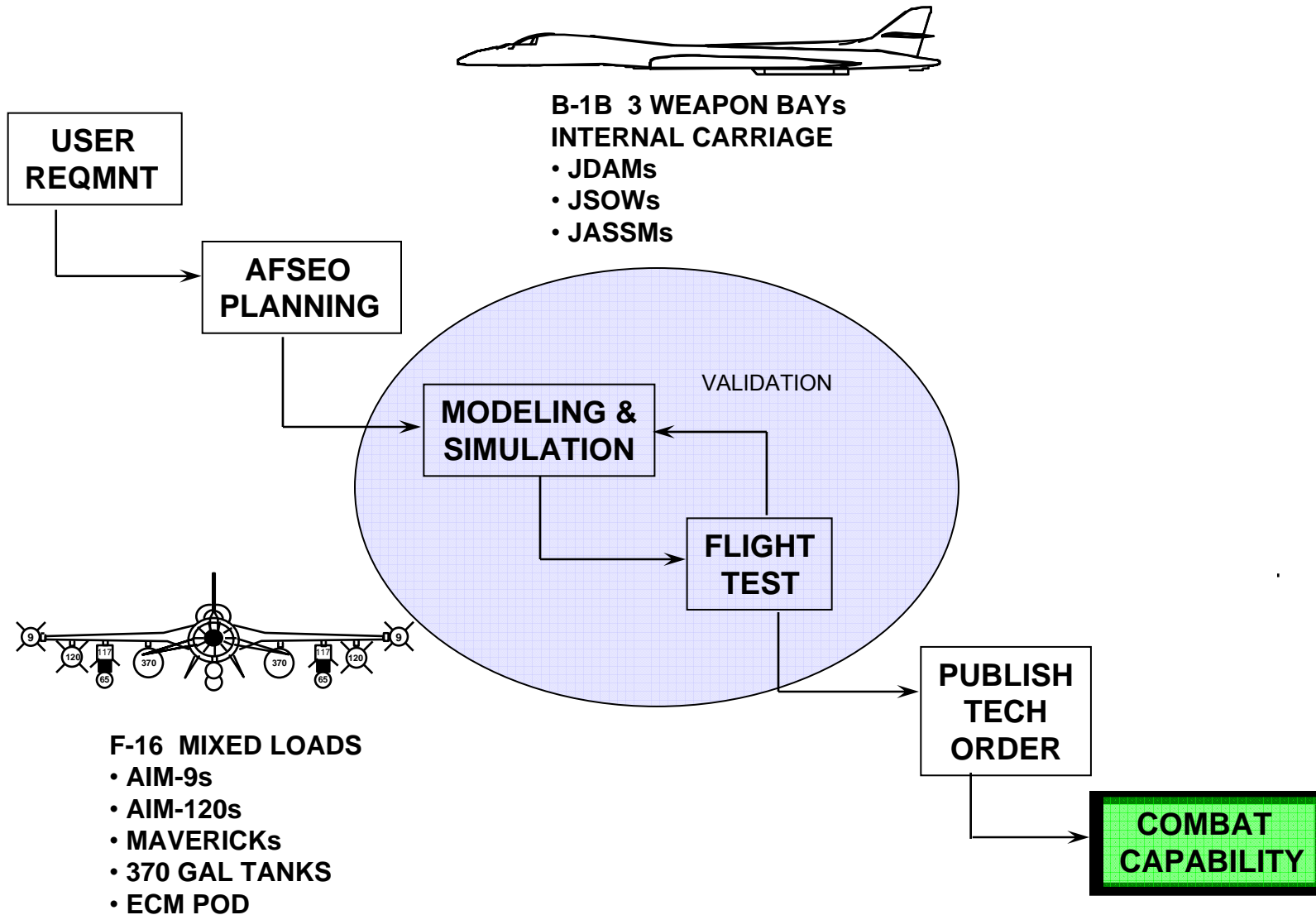

# SEEK EAGLE Process

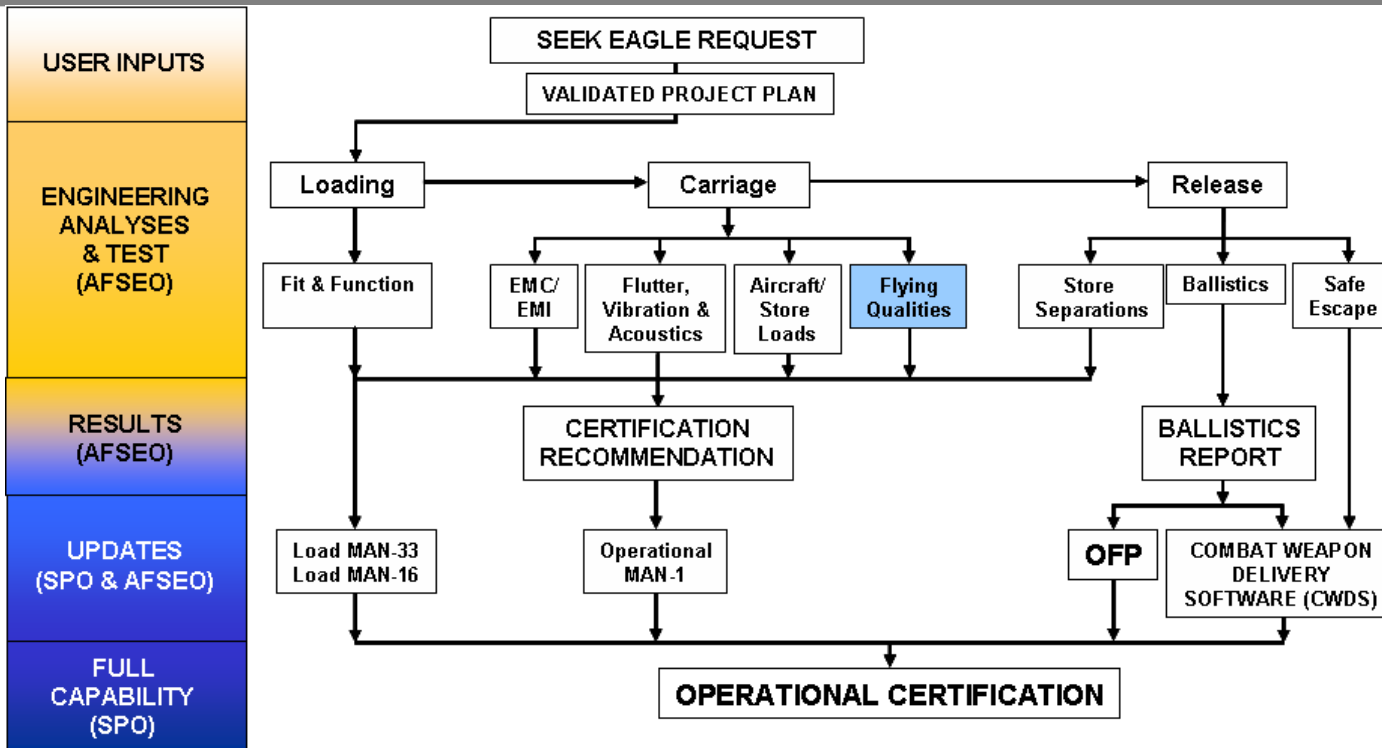

## OVERVIEW

- The SEEK EAGLE program is the standard for the aircraft-stores certification process governed by AFI 63-104 for the US Air Force

## PRODUCTS

- Quick Reaction Certification (QRC)
- Certification Recommendation (CR)
- Flight Clearance (FC)

# Disciplines Use of HPC

---

- **Store Separation**

- 12 – 15 year history of CFD support to SS certification decisions
- Steady solutions of aircraft/stores to determine interference effects
- Time accurate 6DOF solutions of store release from aircraft

- **Stability and Control**

- Current S&C analysis based on analogy/wind tunnel/**flight test**
- CFD capability being developed to simulate aircraft maneuvers in captive carry for ANY configuration – capability will supplement flight test

- **Flutter**

- Analysis primarily uses lower order methods (i.e. panel, transonic small disturbance)
- **Flight tests** become primary clearance method for transonic conditions
- No coupled computational method available for high fidelity analysis (Yet!)

- **Loads**

- Occasional use of CFD to investigate anomalies
- Loads analysis primarily based on reports and wind tunnel data of analogous configurations and **flight test**

# Future Certification Challenge (Flutter Example)

---

## Typical Store Loading - 10 years ago -



### Symmetric Takeoff Configuration Single Weapon Carriage w/std Pylons

- Download permutations = 500
- Critical analytical cases = 80
- Potential test candidates = 10
- **Flight test configurations = 5**

# Future Certification Challenge (Flutter Example)

---

Typical Store Loading  
- 5 years ago -



**Asymmetric Takeoff Configuration  
Single & Multi-Weapon Carriage w/Countermeasure Pylons**

- Download permutations = 2900
- Critical analytical cases = 600
- Potential test candidates = 50
- **Flight test configurations = 20**

# Future Certification Challenge (Flutter Example)

---

## Typical Store Loading - Now -

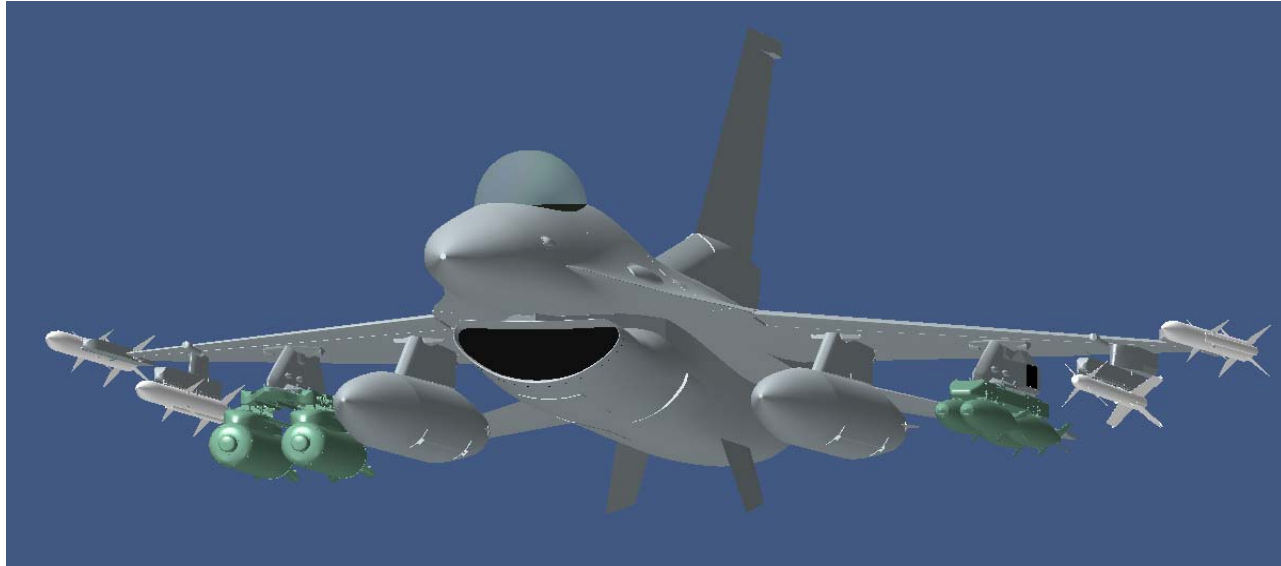

### Complex Asymmetric Takeoff Configuration Multi-Place Weapons Racks & Multiple Countermeasures Pylons

- Download permutations = 25000
- Critical analytical cases = 6200
- Potential test candidates = 250
- **Flight test configurations = 75**

# Future Certification Challenge (Flutter Example)

---

## Typical Store Loading - Now -



Historical average of  
available flight tests  
per year for flutter is 25!  
No expected increase  
for the out years.

Multi-Place

Pylons

- Download permutations = 25000
- Critical analytical cases = 6200
- Potential test candidates = 250
- **Flight test configurations = 75**

# Current Store Separation Use of CFD

---

- Complicated flow physics – transonic, high  $\alpha$  cases
  - Compressibility, interference, shear/boundary layer effects
  - Viscous, flow separation, choked flow, shock waves
  - Multi-body motion, autopilot control, parachutes
- Rapid response – typically 2-6 weeks
  - Time-critical support of flight test
  - Quick turn-around for external customers (warfighter)
- Analysis includes combination of wind tunnel data, CFD solutions, Monte Carlo analysis of sensitivity parameters
- Complex geometry requires large number of CFD grid points (15-60 million)
  - Full or symmetric aircraft
  - Pylons, launchers, etc. – level of detail
  - Store grid

# AFSEO CFD Project Summary

## FY01

F-16/MA-31  
 F-16/Mk-82 fin crack  
 F-15/GBU-27  
**F-16/JASSM**

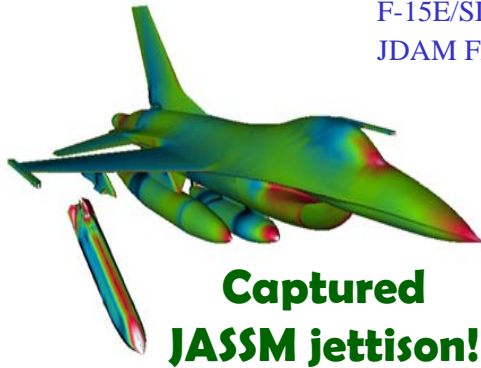

**Captured  
 JASSM jettison!**

## FY02

F-111/SSB  
 F-16/CBU89/JSOW  
 F-16/PPB  
 B-52G/JASSM  
 F-15E/SLV  
 JDAM FZU Sim

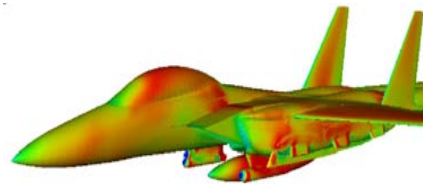

**Realistic fin  
 deployment!**

## FY03

F-15E/JDAM  
 F-15E/SATIRS  
 F-16/SNIPER  
 F-15E/SNIPER  
 F-15E/LITENING  
 F-16/BRU/CBU89  
 B-52H/X-37  
 F-15E WT Support  
 GBU Aero Data  
 F-16/ARGUS  
 F-16/MALD  
**F-15E/WCMD**

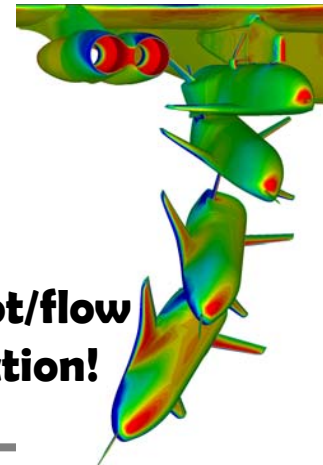

**Autopilot/flow  
 interaction!**

## FY04

B-52H/Mailbox  
 Predator/GBU-12  
 Predator unsteady flow  
 SDB-FTS (GBU-39B)  
 B-52H/JASSM validation  
 BQM-167 rocket plume  
 FZU-55 on MQ-9/GBU-38  
 MALD design studies  
 B-1B/Mk-82/GBU-38  
 F-15E S&C w/CBU-104  
 F-16/600-gal tank  
 B-52H/MALD  
 F-16/MALD  
 F-15E/GBU-28  
 F-16/WCMD-ER  
**B-52H/X-37**

## FY05

B-1B/Mk-82/GBU-38  
 B-1B/IHAAA - turbulence study  
 BQM-167A rocket plume  
 BQM-167A RATO separation  
 MALD design studies  
 B-52H/MALD  
 F-15E S&C w/CBU-104  
 F-15E/GBU-31  
 F-16 w/active control surfaces  
 F-16/600-gal tank  
 F-16/WCMD-ER  
 F-16/ECIPS/MA-31  
 F/A-18C/GBU-12  
 C-130/Store deployment  
 Condensation predictions  
 B-1B/SNIPER/GBU-38  
 F-15E/GBU-28B/B  
 F-15E/SNIPER/GBU-38  
 F-15E/BRU61/GBU-39/B (SDB)  
 B-52/GBU-12 SafetyIB  
 B-2A/GBU-28  
 JSF-CTOL/AIM-9X  
 JSF-CV/AIM-9X  
**F-16/MALD**

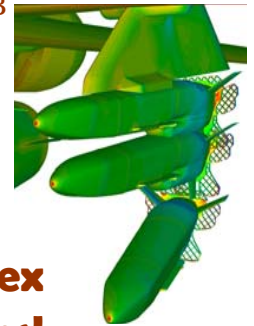

**Complex  
 grid fins!**

# AFSEO CFD Project Summary (Cont.)

## FY06

F-16/WCMD-ER

GBU-38 WT

F-15E/GBU-38 Condensation

F-16/AIM9X-9L Flutter

B-52/GBU-38

B-52/GBU-12B

F-18/GBU-12B

JSF-CTOL/Aim-9X

BQM-167/AFSAT

F-15E/SDB

MK-82 WT

F-15E/AGM-158

B-1 Cavity study

F-16/JSOW

F-15E/GBU-38

YMQ-9A/GBU-12B

F-15E/GBU-31 Condensation

F-16/Tanks S&C

B-2/GBU-28

F-15E/GBU-28C/B

F-16/MALD

JSF Bay Study

*B-52/MALD*

F-15E/SNIPER/GBU38

F-16/MA-31

B-1/GBU38-MK82

F-15C/AIM-54C

F-16/GBU-39

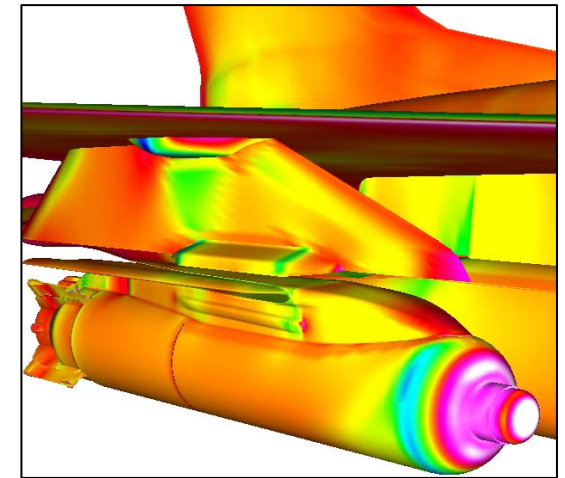
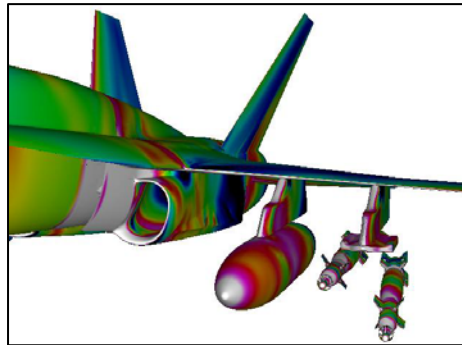
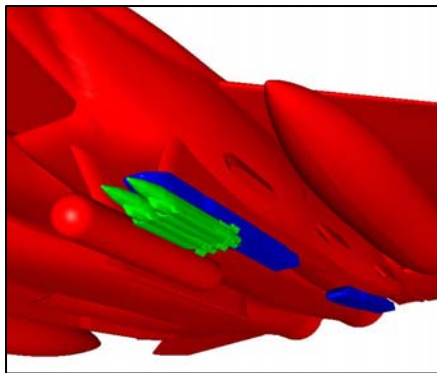
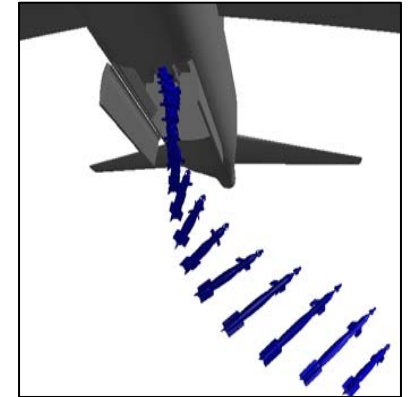
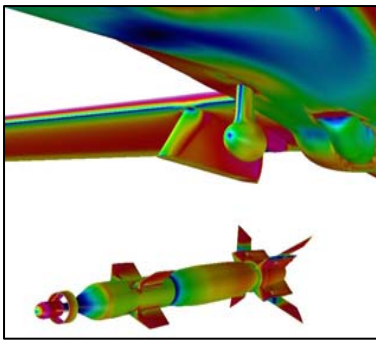

# Store Separation Example – B-52/MALD

---

## MALD Separation CFD

- 13 carriage solutions
- 20 separation trajectories
- 6,992 CFD Solution Points

## Case Management Software

- Tower at ERDC, ARL
- ~2.5 million CPU-hours
- Project not possible w/out HPC support

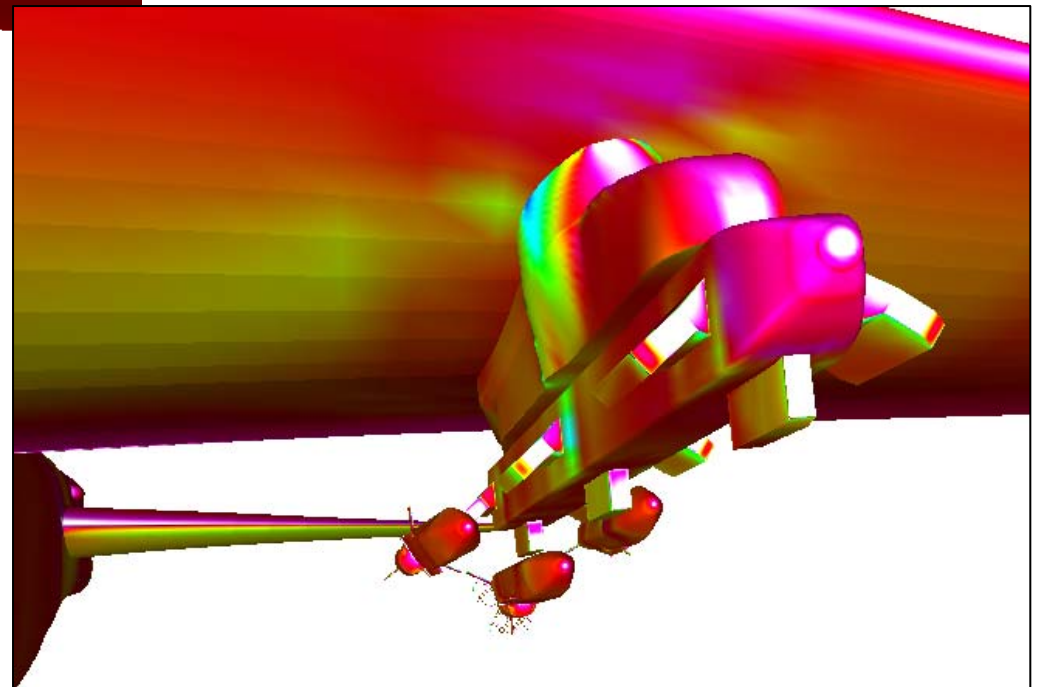
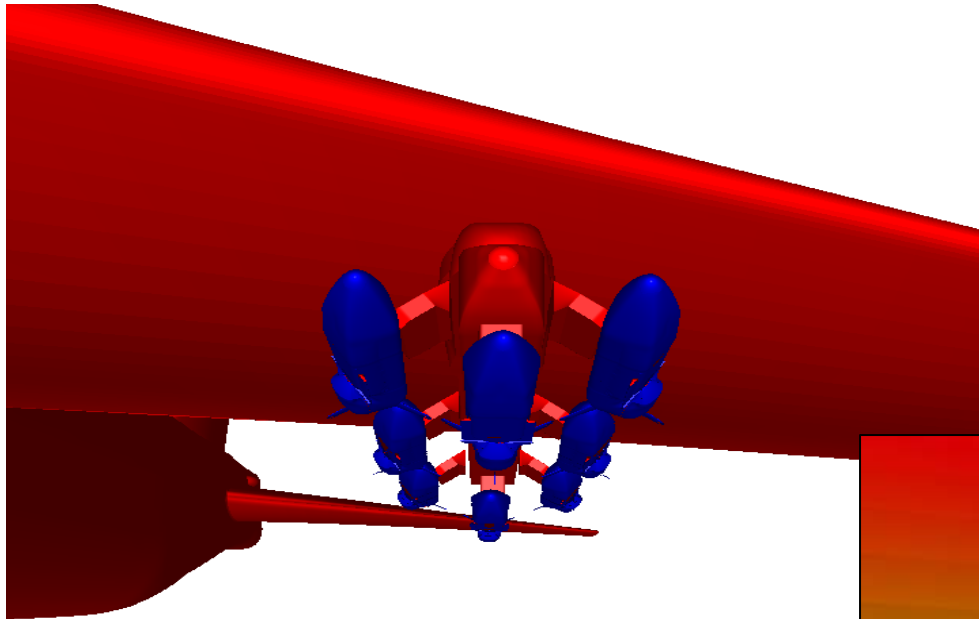

# Store Separation Example – F-16/GBU-39

---

F-16/BRU-61/SDB integration and certification effort

- 15-35 million cell problem
- 33 trajectories in total
- Led to initial flight clearance for flutter flight testing

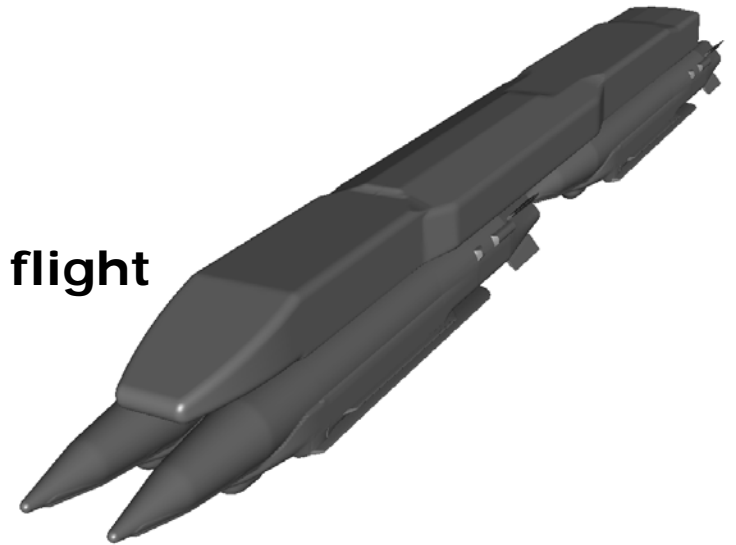
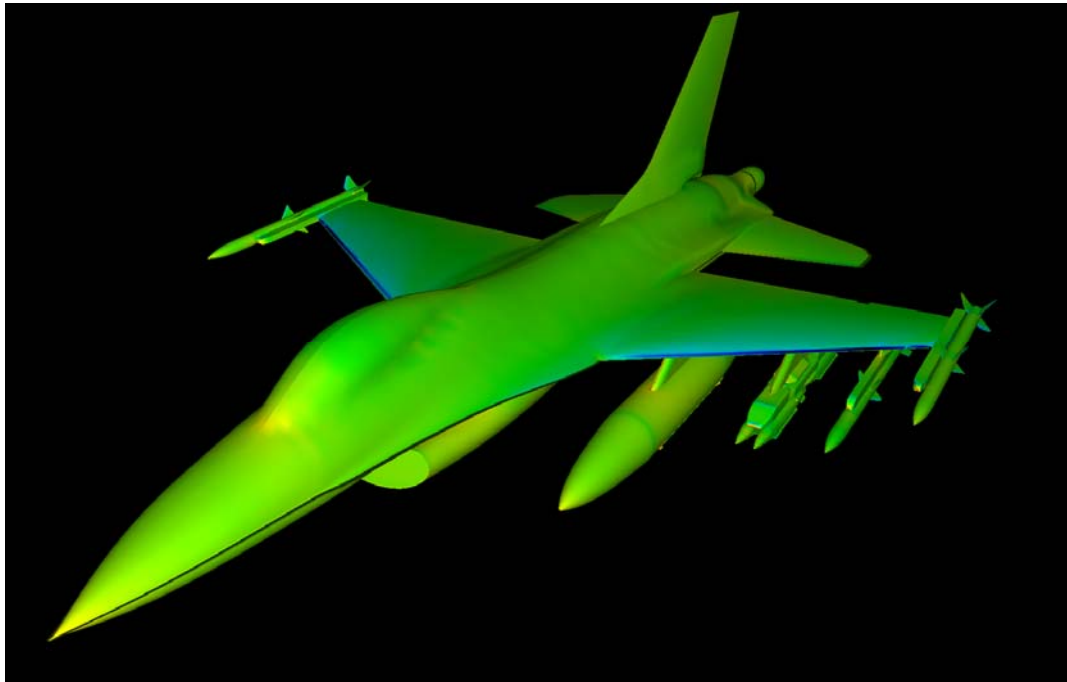

**Over 10,000 CFD Solutions required to perform the analysis of the Small Diameter Bomb!**

# Current Stability & Control Challenges

---

- **Determine the impact external stores have on aircraft flying qualities**
- **Ensure all configurations meet weight and balance requirements**
- **Three methods to clear a configuration—analogy, wind tunnel test, and flight test**
- **Analogy**
  - Most stores are similar in aerodynamics and mass properties
  - Small changes can also be analyzed this way
- **Wind tunnel testing**
  - Static stability only
  - Expensive and time consuming for good answers
- **Flight testing**
  - Most expensive, but most robust
  - Fully-instrumented, quantitative, monitored test
  - Un-instrumented, qualitative, captive flight profile test → pilot assessment, Cooper-Harper/PIO rating system

# Current Stability & Control Challenges

---

- **No computational S&C capability (static or dynamic)**
- **F-16 and F-22 ATLAS aerodynamic database limitations:**
  - Limited in the number of configurations
  - Only symmetric configurations available
    - Many S&C problems arise when asymmetries present
  - No data for modern stores and suspension equipment
    - TGP (LANTIRN only)
    - Multi-carriage rack systems
    - Guided weapons w/ wing & tail kits, odd shapes, etc.
- **Unable to accurately predict where instabilities occur in the flight envelope and their nature, if they occur at all**
- **Unable to accurately predict departure resistance and boundary layer separation for high AOA testing of new configurations**

# Developing New Approach for S&C

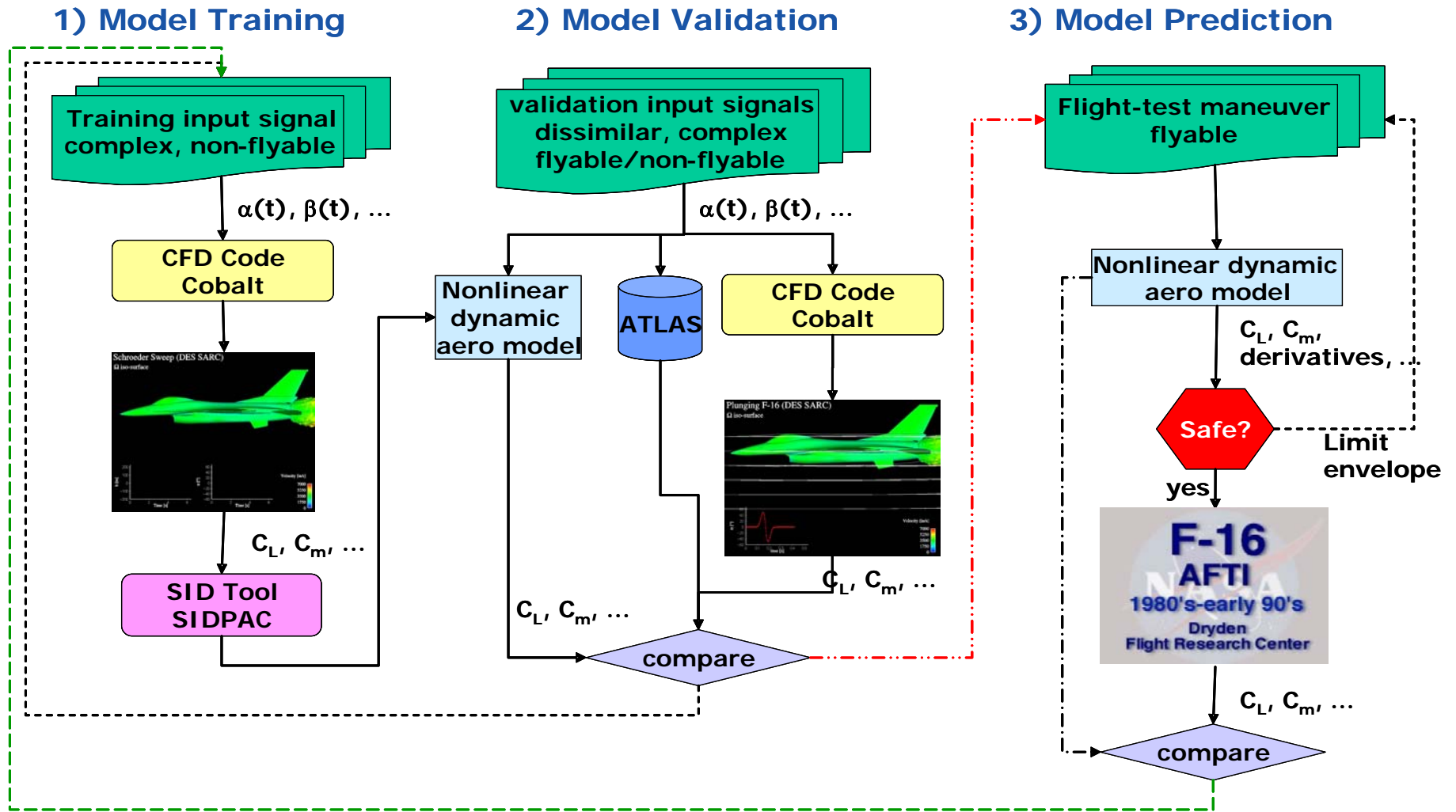

# Composite Pitch-Yaw DC Chirp

- Composite PitchYaw DC Chirp maneuver allows a single motion input to create a model including motion about two axes
  - $\alpha = 15_{\pm 15}$  deg,  $\beta = 0_{\pm 15}$  deg
- Input signal is made orthogonal by setting  $\lambda$  to 1.0 for pitch and varying  $\lambda$  until dot product of the two signals is zero resulting in  $\lambda$  of 1.47 for yaw signal
- Requires full span F-16C grid

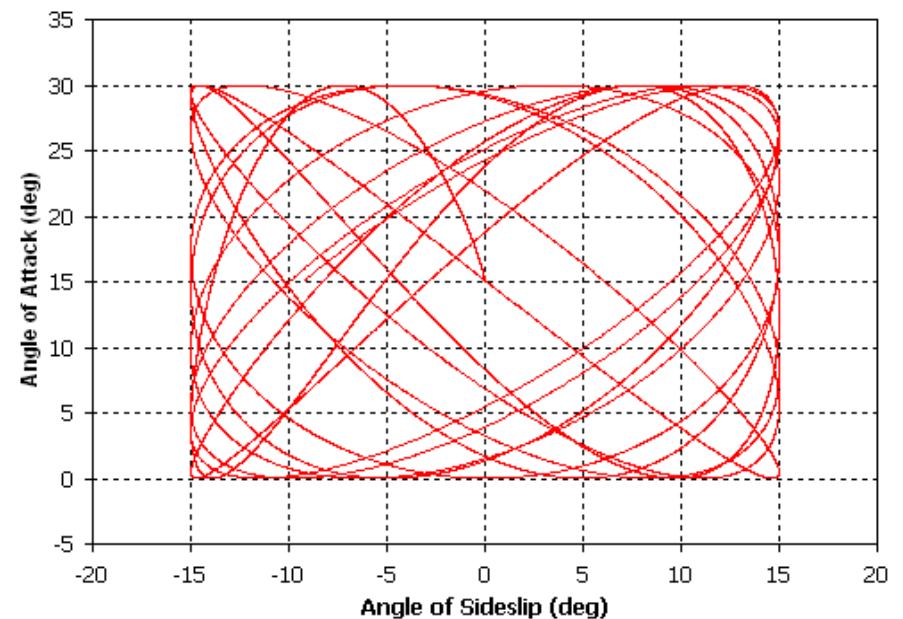
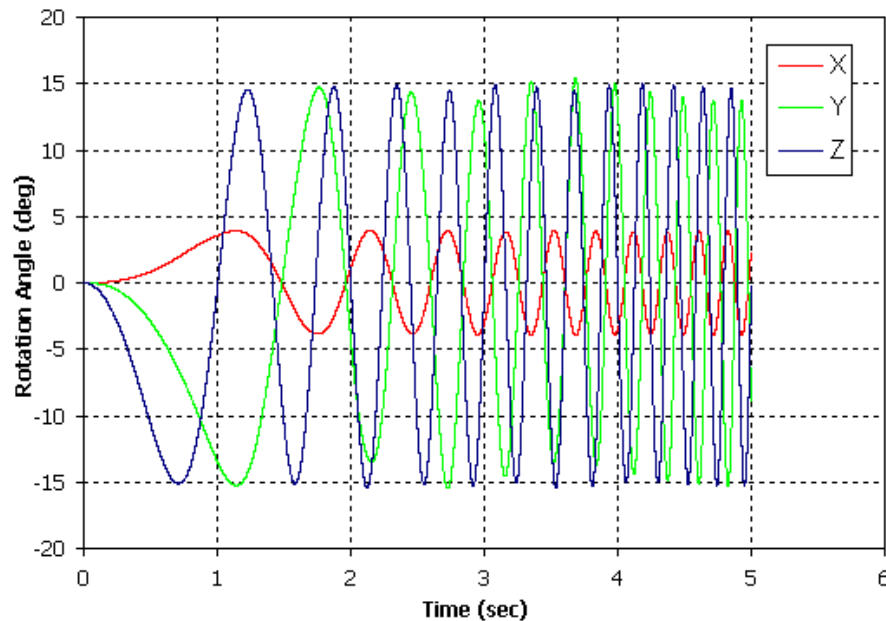

# Composite Pitch-Yaw Chirp

Simulation run at  $M=0.6$  and  $h=5,000$  ft with full span grid

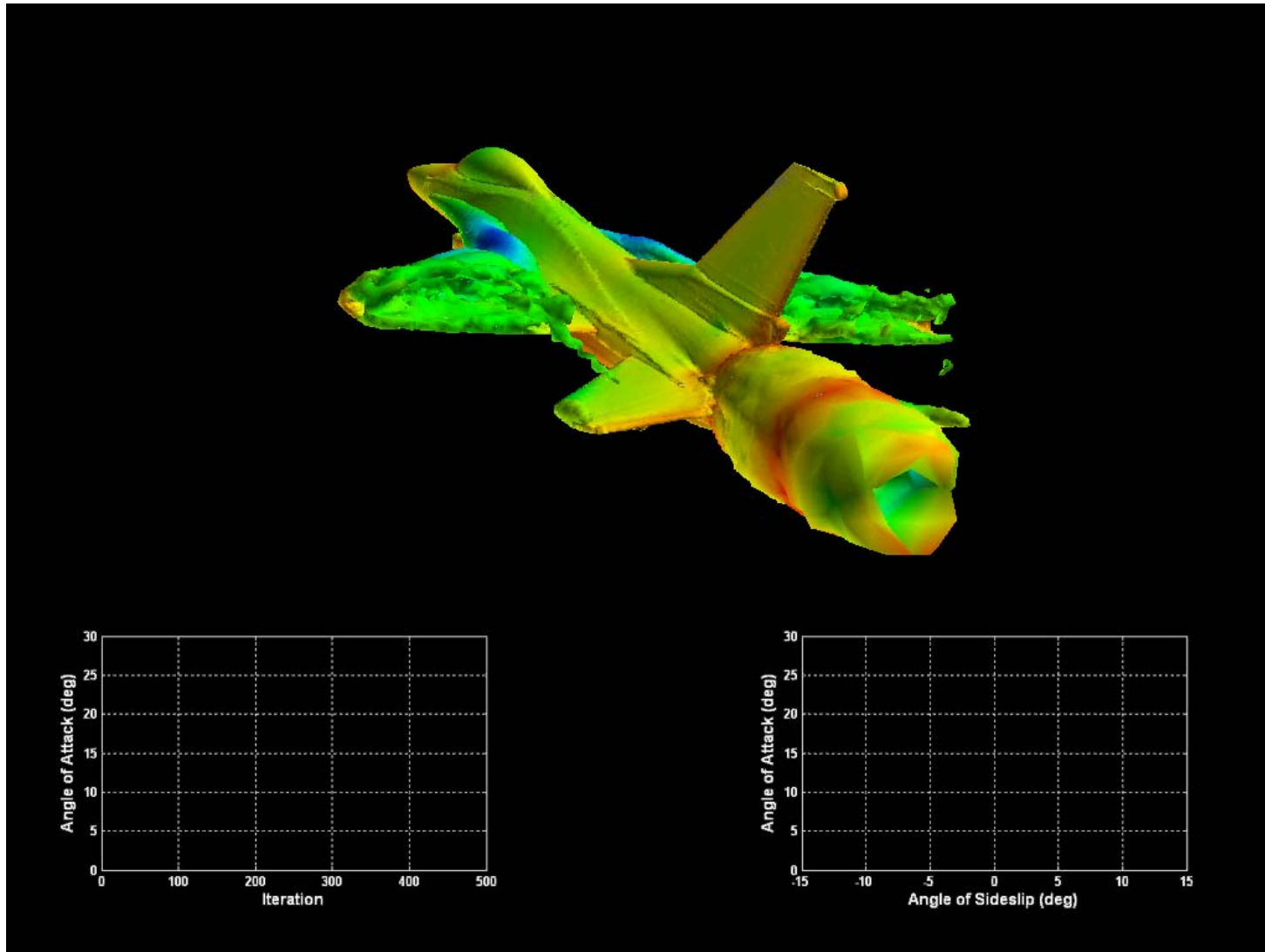

# System ID of Pitch-Yaw Chirp

- SIDPAC Model:

$$C_L(\alpha, \beta, p, q, r) = C_1 + C_2\alpha + C_3q + C_4p^2 + C_5\alpha q^2 + C_6\beta p q$$

$$C_7\beta p + C_8\alpha^2 q + C_9r + C_{10}\alpha\beta^2 + C_{11}\alpha^3 + C_{12}pr +$$

$$C_{13}\beta^2 p + C_{14}\beta^2 q + C_{15}p + C_{16}\beta^2$$

- Validated against static  $C_L$ - $\alpha$  data and single axis motion pitch chirp

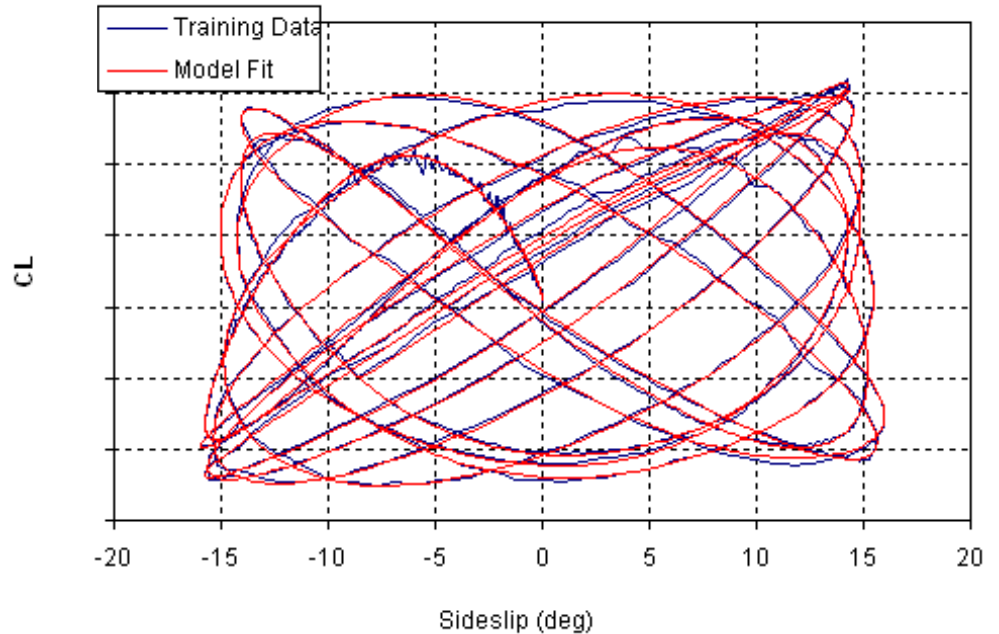

**Model Prediction for CL**

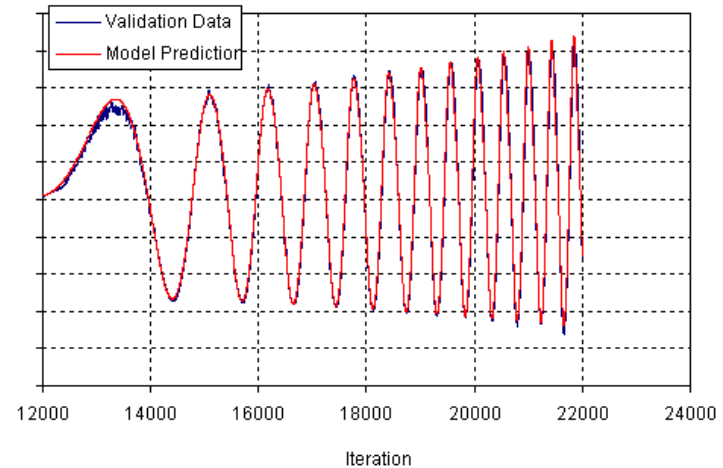
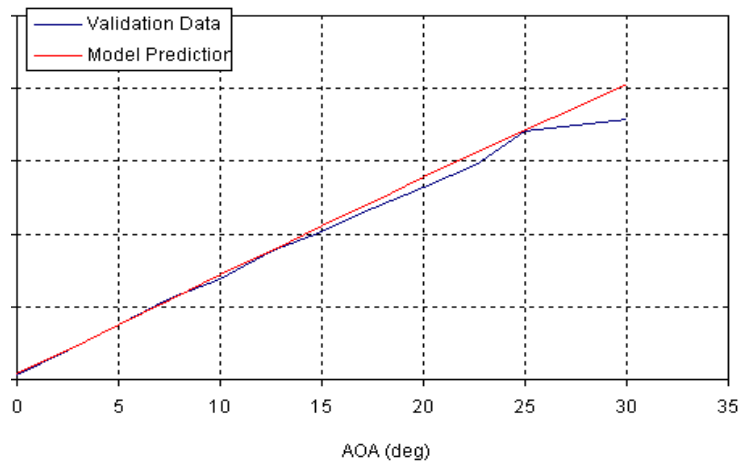

# 2.5g Wind Up Turn Flight Test Maneuver

- Gathered actual strip chart data from a flight test
- Created the motion file that forces the F-16C through translations and rotations resulting in the Wind Up Turn observed in flight
- Also used the reduced order loads model to perform the maneuver and compared them

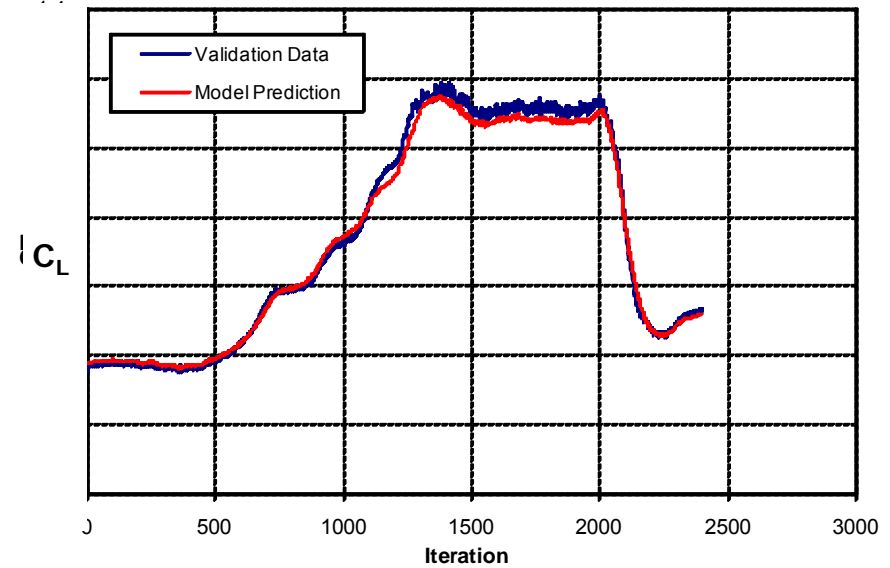
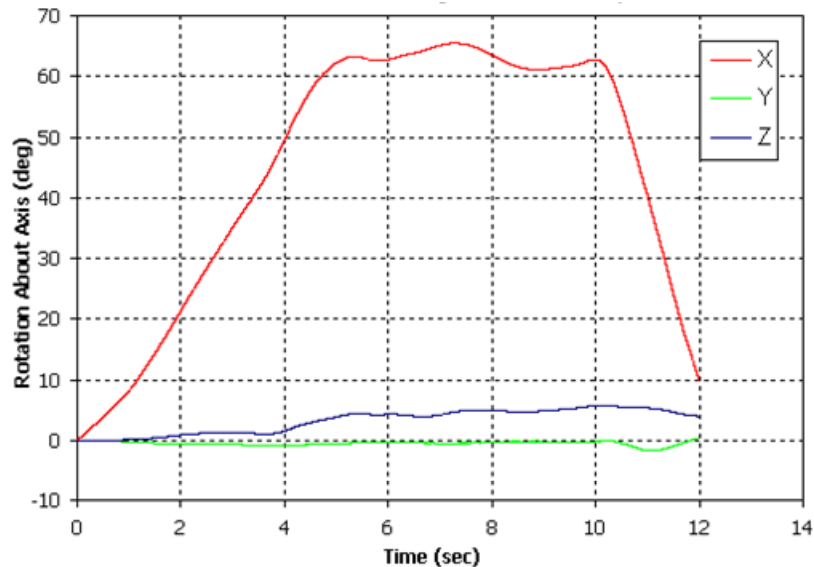

# 2.5g Wind UpTurn Flight Test Maneuver

Simulation run at  $M=0.6$  and  $h=5,000$  ft with full span grid

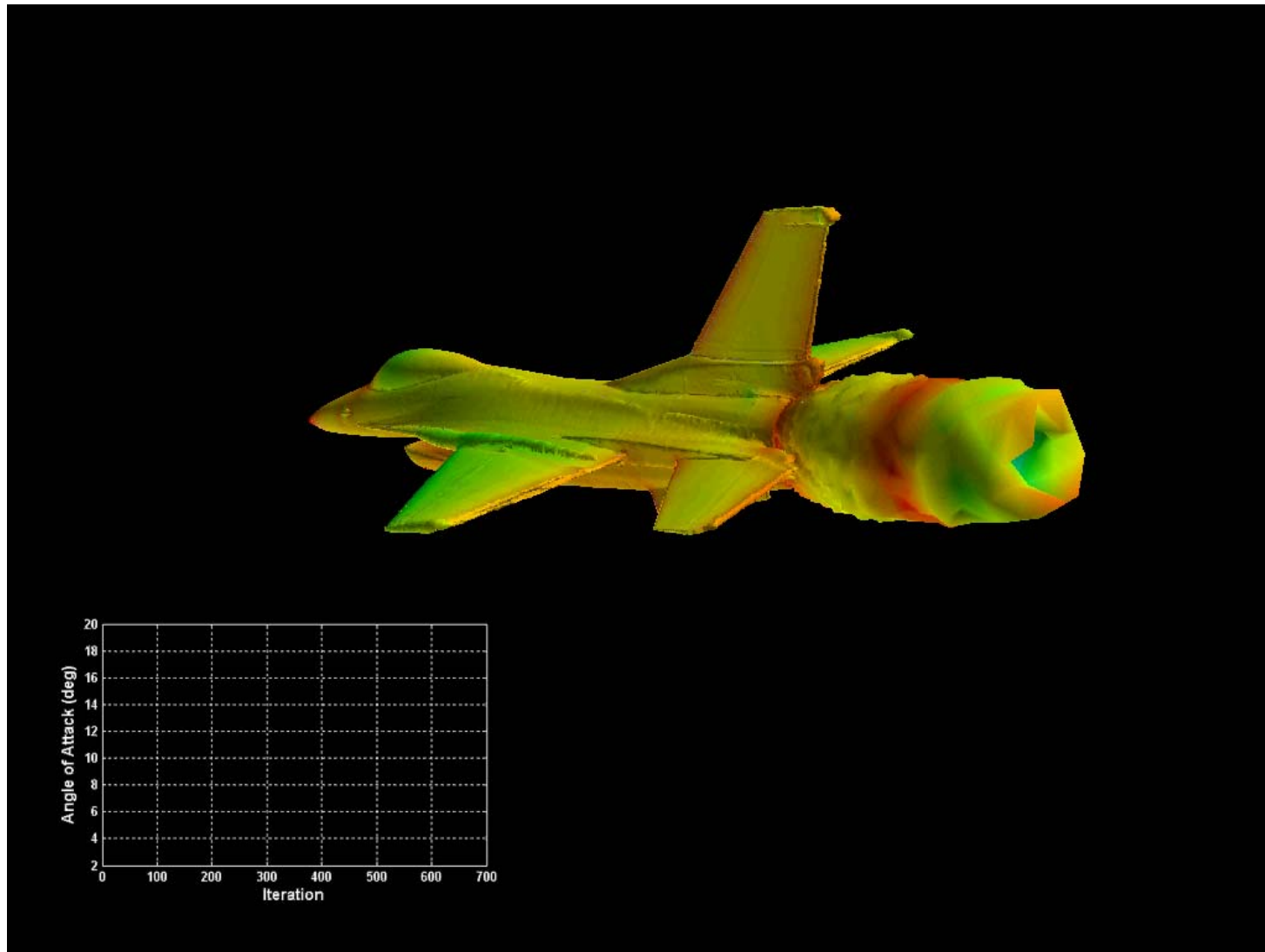

# Static Validation vs. CFD/ATLAS

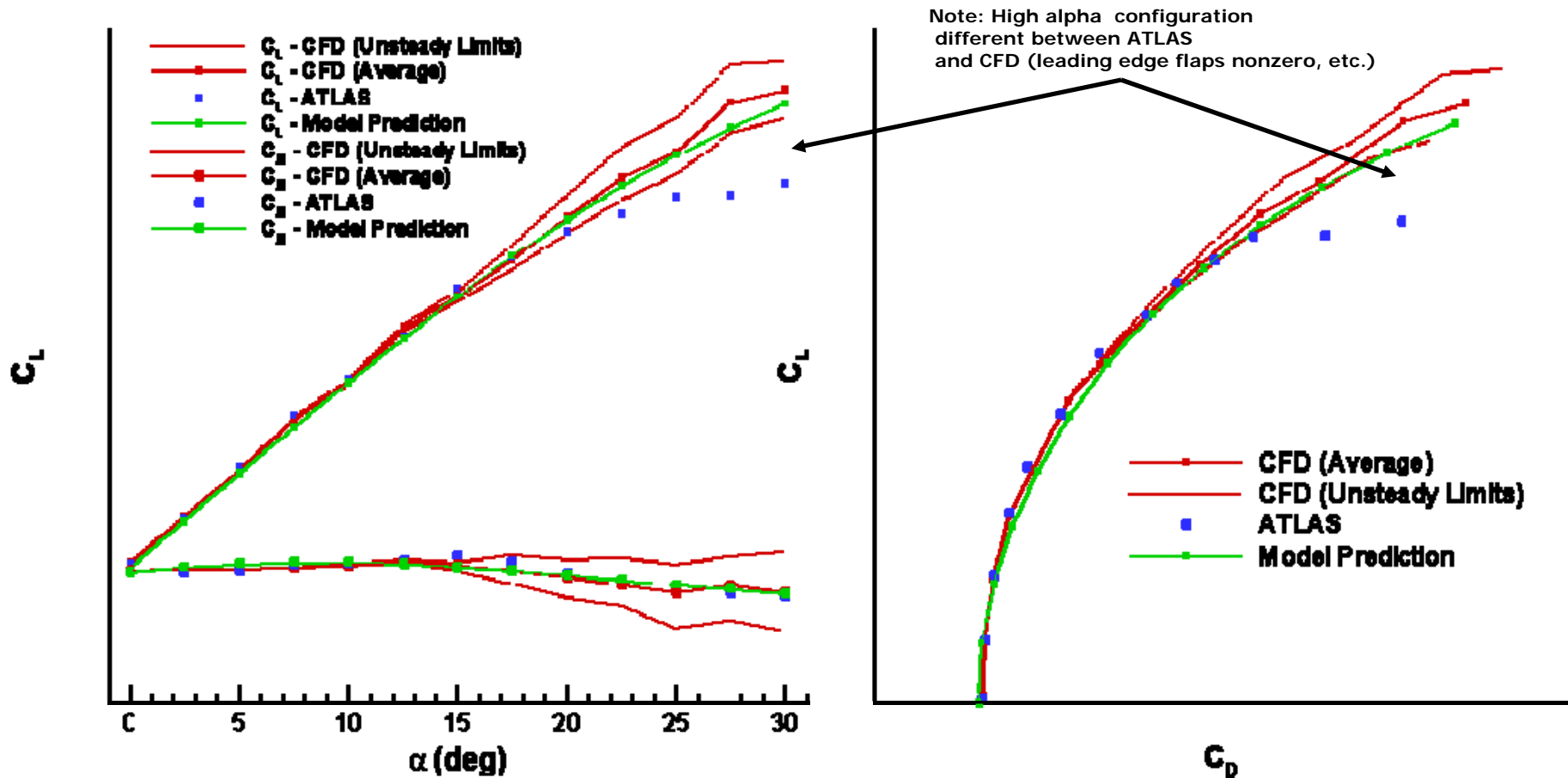

# Ultimate Goal

- Integrate all modules into high-fidelity tool capable of accurately modeling full elastic aircraft/armament configurations

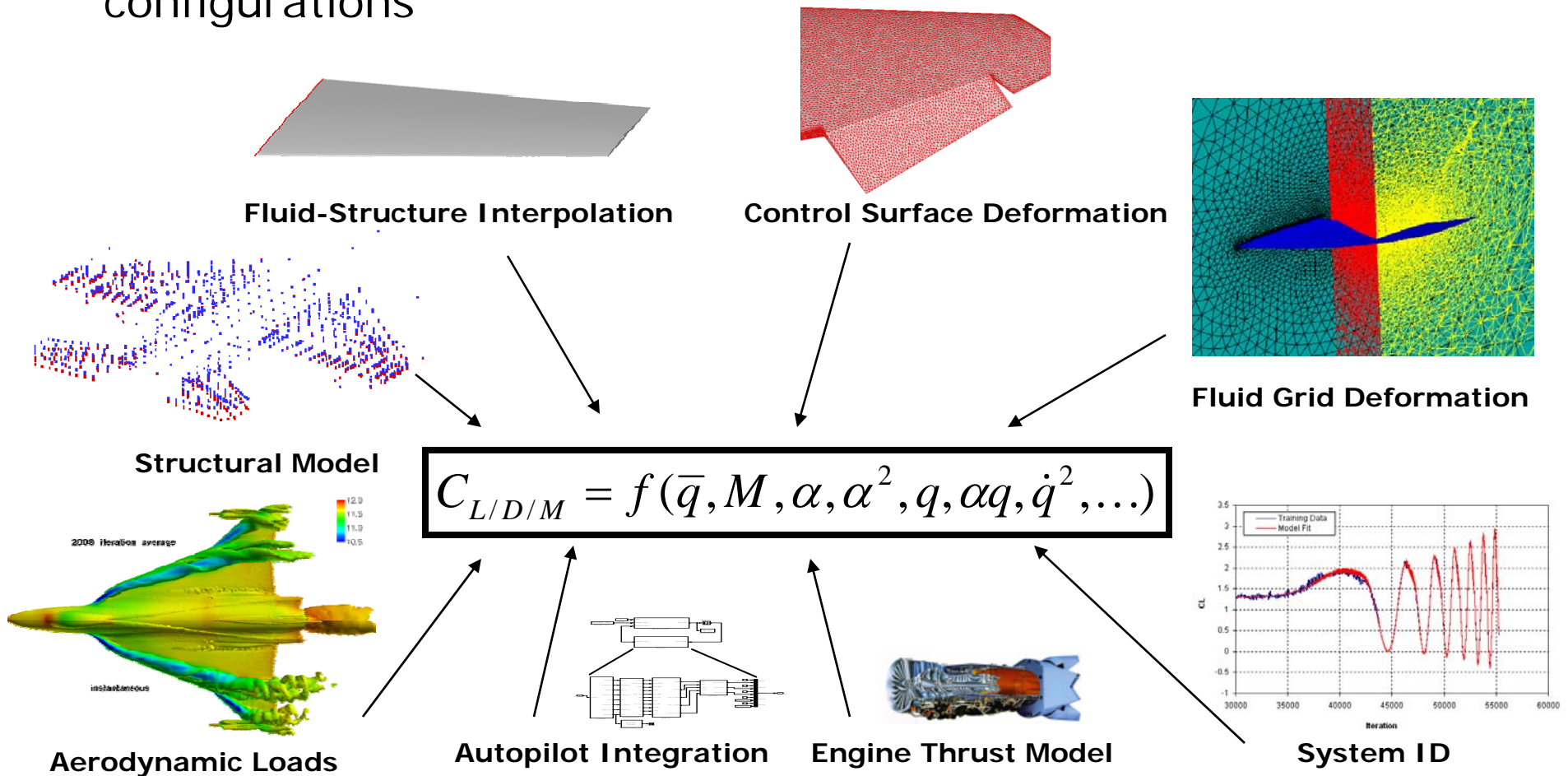

# DoD HPC CREATE-AV Product

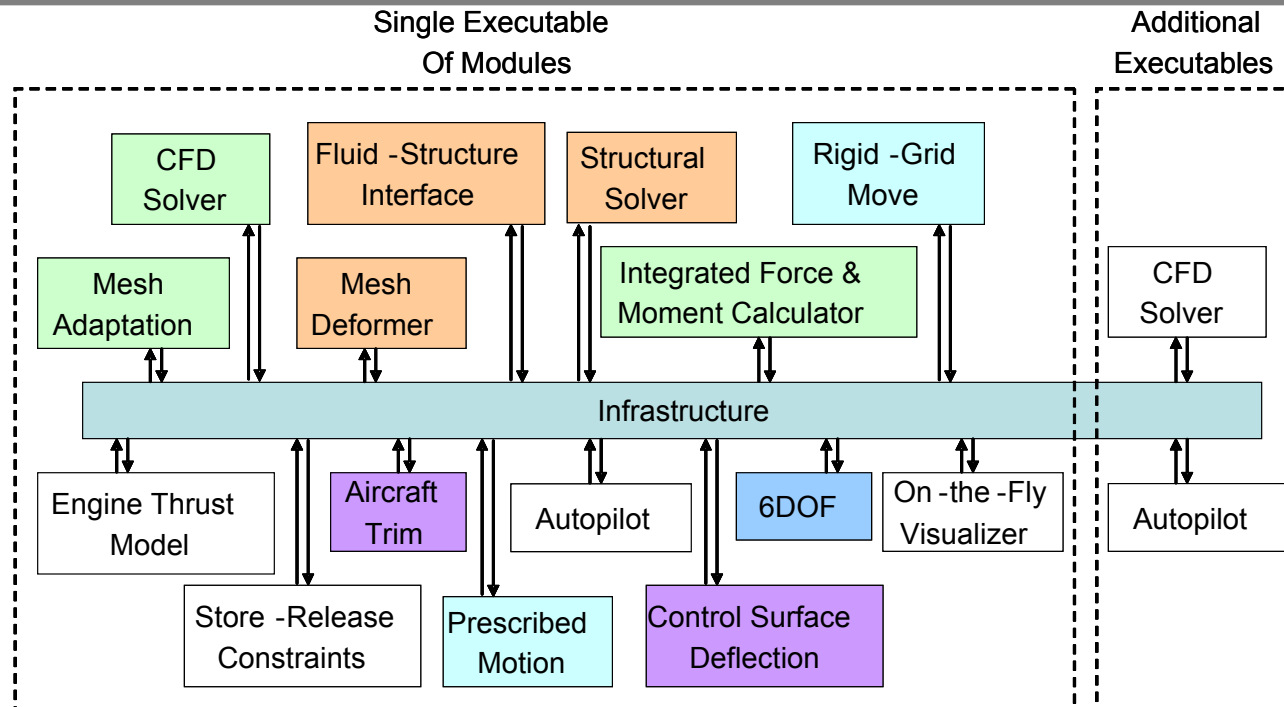

## *Kestrel* Fixed Wing Virtual Aircraft Description

- Cross-over between aerodynamics, stability and control, structures, propulsion, store separation
- Improved performance on parallel architectures with from  $10^4$  to  $10^6$  cores (giga-flop to peta-flop)
- Fixed wing vehicle in the subsonic, transonic, and supersonic flight conditions
- Maneuvering aircraft, multiple aircraft tracked, in operations of refueling, carrier landings, etc.
- **KIE** Infrastructure and Executive in Python, **KUI** Graphical User Interface in wxPython
- Components programmed in F90/95/03 and C
- All APIs and data structures for components consistent across CREATE-AV products

# Notional Delivery Schedule

---



**KIE Design Complete – End of 2Q FY08**

**KUI Design Complete – End of 2Q FY08**

**Spiral One Phase One – End of 2Q FY09**

•**Static Rigid Body Aircraft & Captive Store**

•Single Grid, Multiple Grids Stitched

•**Dynamic Rigid Body Aircraft & Captive Store**

•Single Grid with Prescribed Motion

•**Flexible Aircraft**

•Static Position Single Grid Aeroelastic

•**Regression Test Implementation for Spiral 1 Phase 1**

**Spiral One Phase Two – End of 4Q FY09**

•**Static Rigid Body Aircraft & Captive Store**

•Single Grid Control Surface Move, Multiple Grids

•**Dynamic Rigid Body Aircraft & Captive Store**

•Single Grid with 6DOF Motion

•**Static Rigid Body Aircraft & Dynamic Store**

•Multiple Grids with Prescribed Store Motion

•**Flexible Aircraft**

•Flexible Aircraft and Captive Store Motion

# Notional Delivery Schedule

---



## **Spiral One Phase Three – End of 2Q FY10**

- **Dynamic Rigid Body Aircraft & Captive Store**
  - Single Grid with Autopilot, 6DOF Store Motion
  - Single Grid with Dynamic Propulsion, Autopilot, 6DOF, and Trim
- **Static Rigid Body Aircraft & Dynamic Store**
  - Multiple Grids with 6DOF Store Motion
  - Multiple Grids with 6DOF Store Control Surfaces

## **Spiral One Phase Four – End of 2Q FY11**

- **Dynamic Rigid Body Aircraft & Captive Store**
  - Multiple Grids with Dynamic Propulsion, Autopilot, 6DOF, and Trim
- **Dynamic Rigid Body Aircraft & Dynamic Store**
  - Multiple Grids Prescribed Aircraft Motion, and 6DOF Stores
  - Multiple Grids, 6DOF Aircraft Motion, and 6DOF Stores
- **Flexible Aircraft**
  - Dynamic Flexible Aircraft and Captive Stores
  - Dynamic Flexible Aircraft and Dynamic Stores

## **Spiral Two Phases focus on Performance on Peta-flop machines and code development for maintainability – FY10 – FY18**

# Summary

---



- **AFSEO has been using HPC for 12 – 15 years in Store Separation Certification**
  - Exponential growth in configurations
  - Case management as important as performance
- **AFSEO changing workflows in Stability and Control, Loads, and Flutter to include HPC in certification decisions**
  - New process for S&C and Loads using reduced order loads model
  - New software needed for Flutter
- **DoD HPCMP CREATE Program**
  - Kestrel Fixed Wing Virtual Aircraft Software Product
  - Full capability being developed in prototype over first 3 years
  - Performance and scalability over the life of the program (12 years +)



---

# Questions?

