

Advancing Scientific Discovery with Quantum Computing

Travis S. Humble
Quantum Computing Institute
humblets@ornl.gov

*An overview of the ORNL vision and
capabilities for quantum computing*

ORNL is managed by UT-Battelle, LLC for the US Department of Energy

Oak Ridge National Laboratory



High-performance Computing

Scientific discovery and innovation depend on advances in computational capability



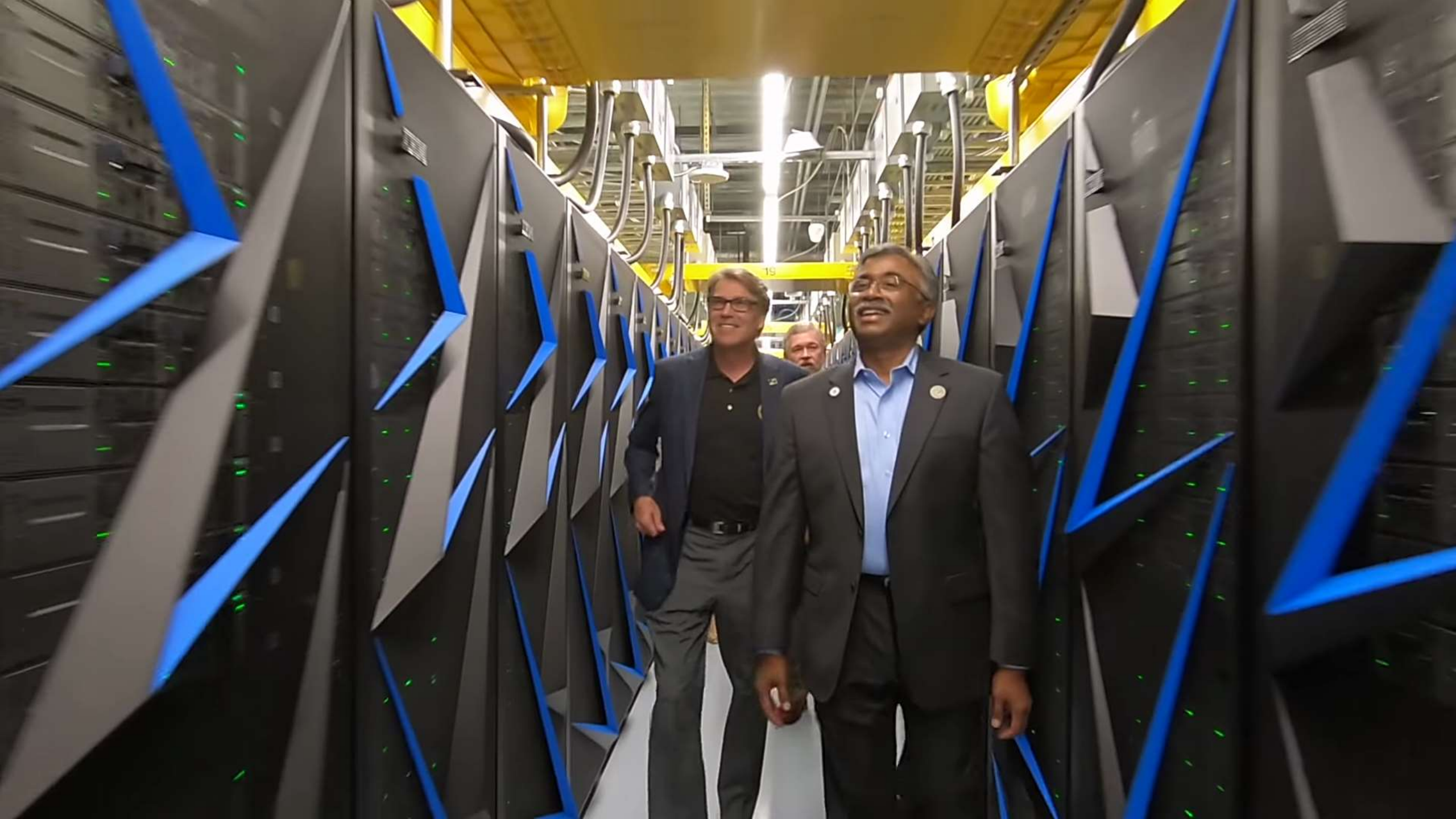

Microelectronics continue to advance

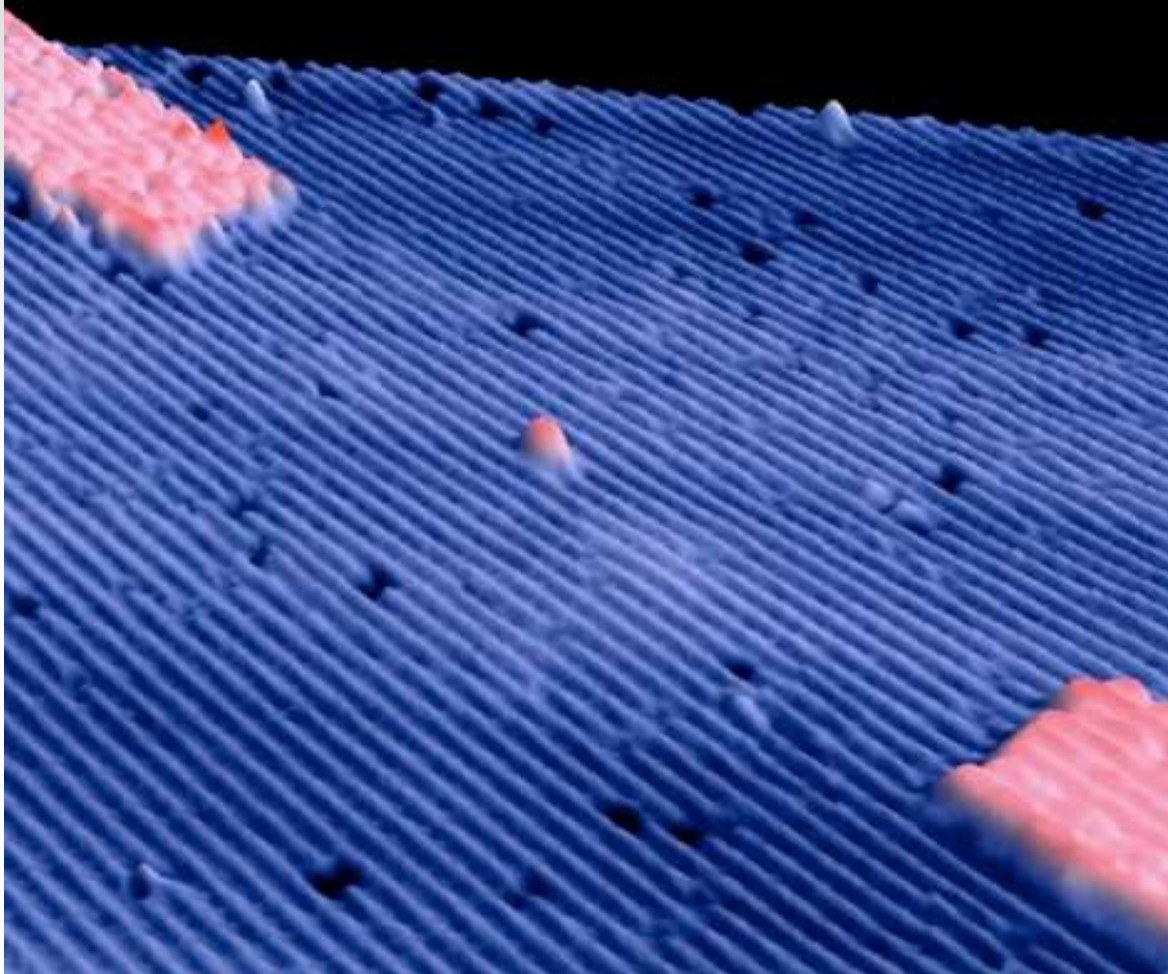

New capabilities yield new opportunities

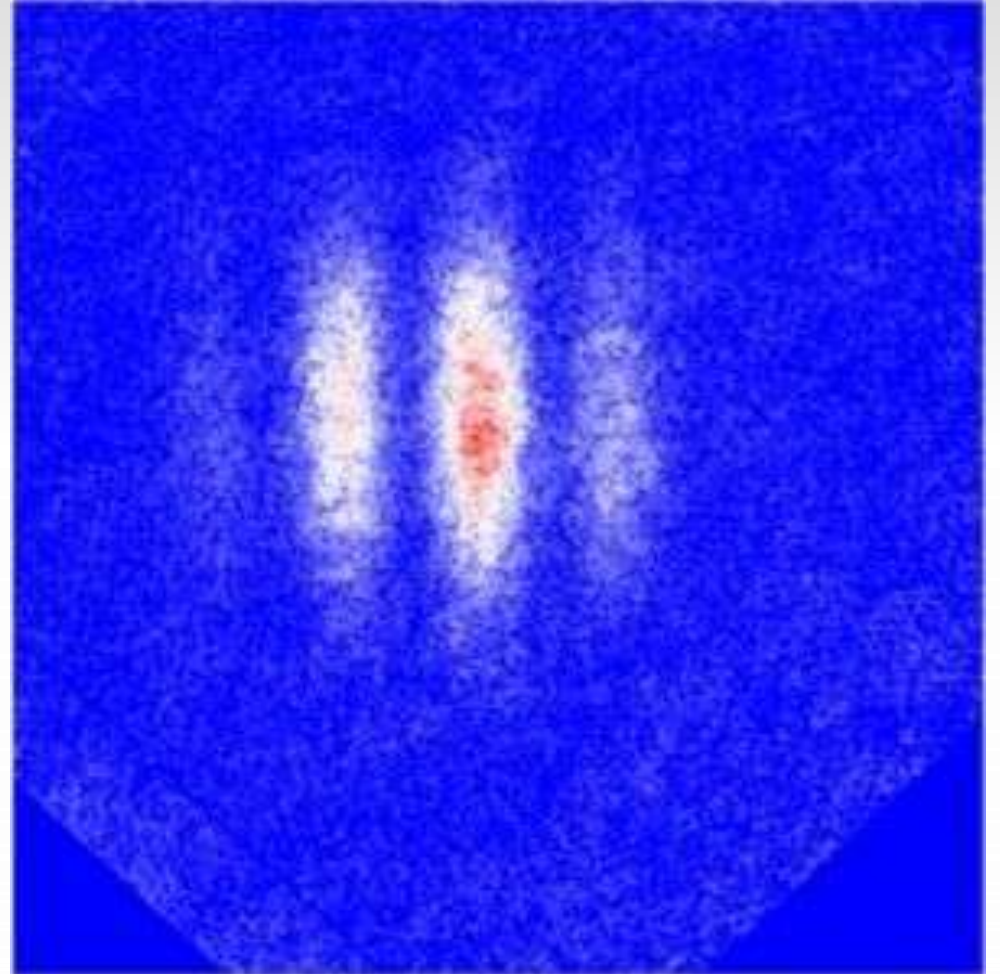

“If you want to make a simulation of nature, you'd better make it quantum mechanical, and by golly it's a wonderful problem, because it doesn't look so easy.”

Richard Feynman, *Simulating Physics with Computers*

(1982)

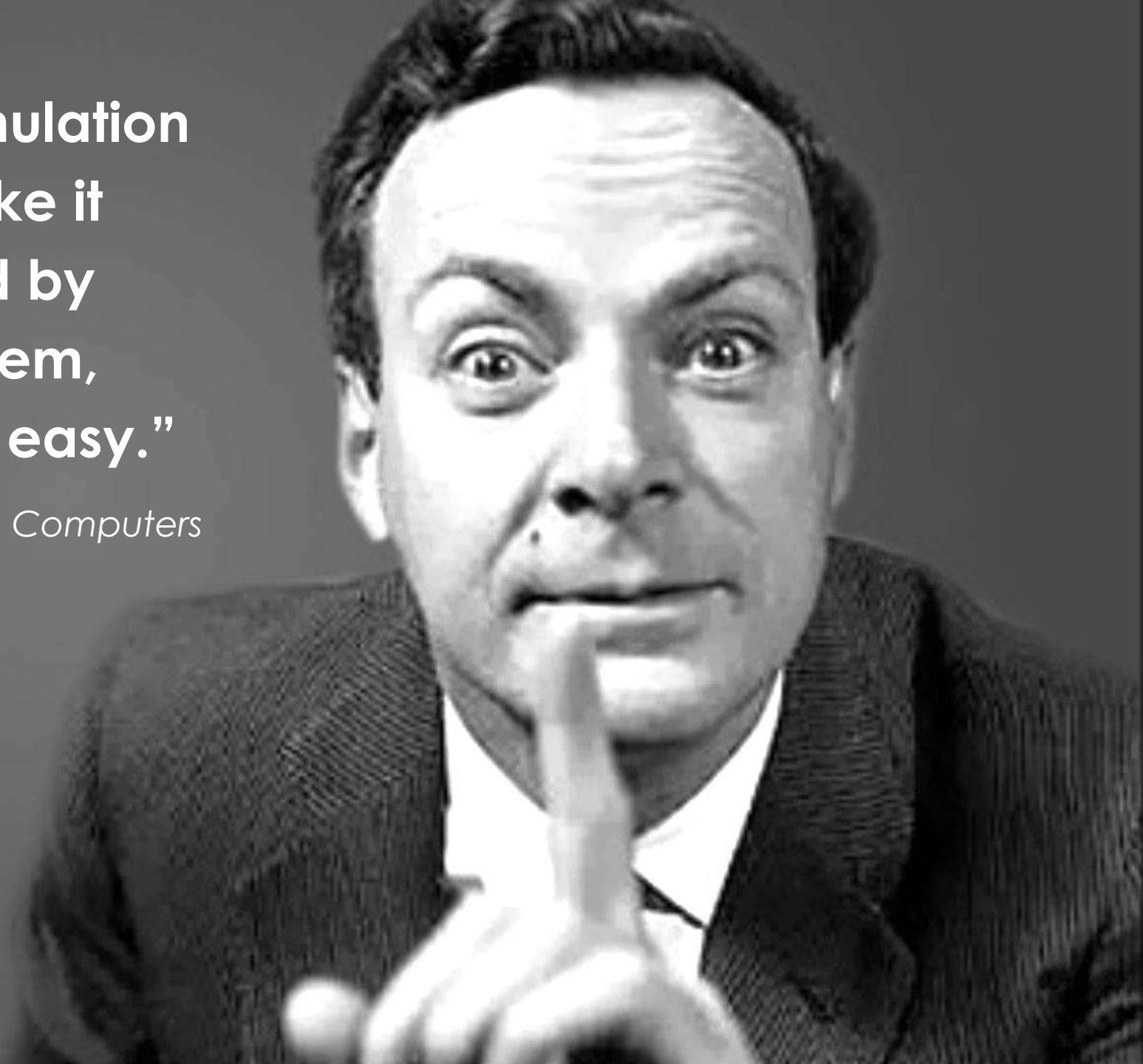

What is Quantum Computing?

- Quantum mechanical computation
 - In quantum mechanics, the *wave function* describes all knowledge about the system
- Quantum computing manipulates the wave function to perform calculations
 - Quantum dynamical control of the Hamiltonian corresponds to computation

$$i\hbar \frac{\partial \Psi(t)}{\partial t} = H(t) \Psi(t)$$

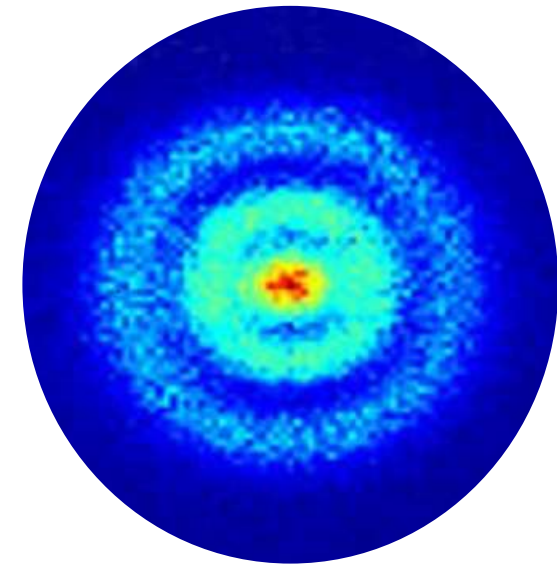
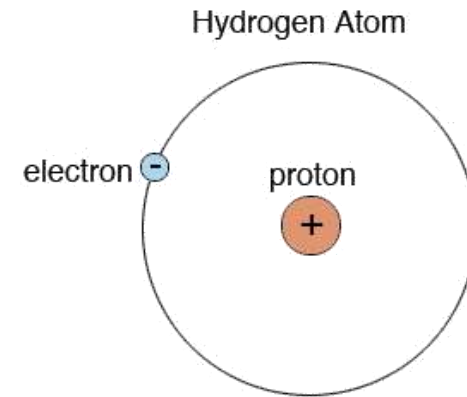

Stodolna et al. PRL 110, 213001 (2013)

Basic Requirements of a Quantum Computer

D. DiVincenzo, "The Physical Implementation of Quantum Computation," (2000)

- A scalable system of well-characterized qubits
- The ability to initialize qubits in well-defined fiducial states
- A universal set of quantum gates
- Decoherence times much longer than gate operation times
- A qubit-specific measurement capability
- The ability to swap qubit locations
- The ability to move qubits

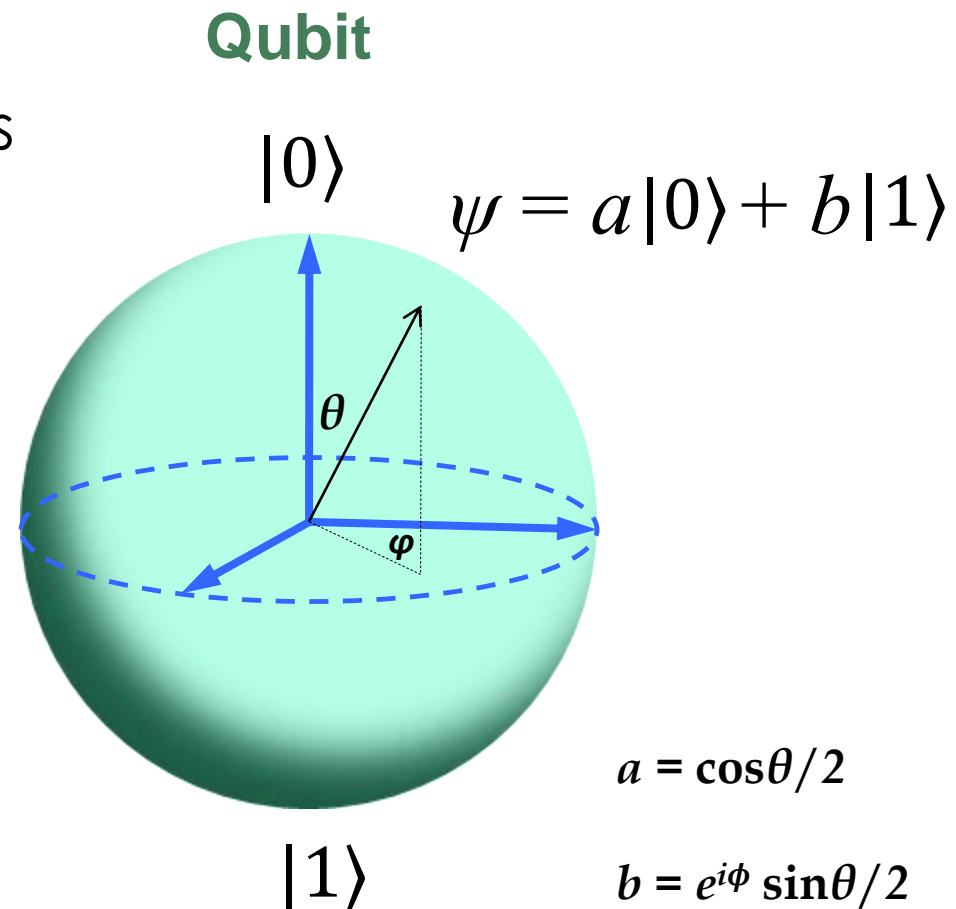

A Race for Quantum Technology

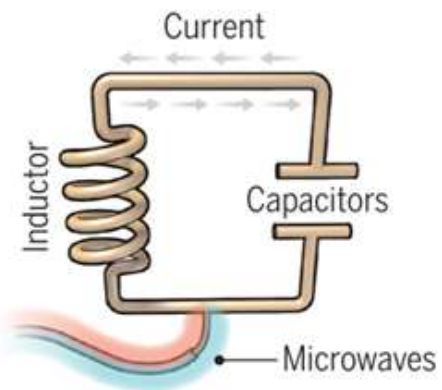

Superconducting loops

A resistance-free current oscillates back and forth around a circuit loop. An injected microwave signal excites the current into superposition states.

Longevity (seconds)

0.00005

Logic success rate

99.4%

Number entangled

20

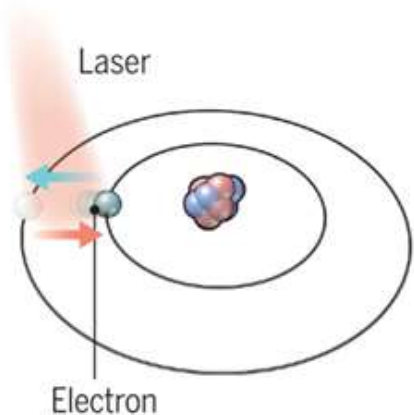

Trapped ions

Electrically charged atoms, or ions, have quantum energies that depend on the location of electrons. Tuned lasers cool and trap the ions, and put them in superposition states.

>1000

99.9%

22



Silicon quantum dots

These "artificial atoms" are made by adding an electron to a small piece of pure silicon. Microwaves control the electron's quantum state.

0.03

~99%

2

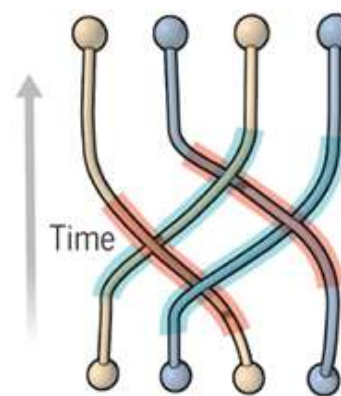

Topological qubits

Quasiparticles can be seen in the behavior of electrons channeled through semiconductor structures. Their braided paths can encode quantum information.

N/A

N/A

N/A

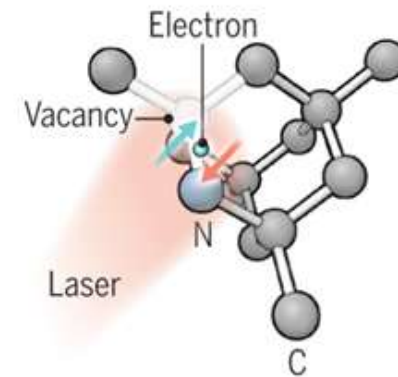

Diamond vacancies

A nitrogen atom and a vacancy add an electron to a diamond lattice. Its quantum spin state, along with those of nearby carbon nuclei, can be controlled with light.

10

99.2%

6

Quantum Processing Units

- QPU's are devices that implement the principles of digital quantum computing
 - Several different maturing technologies
 - Small register sizes (0-22)
 - Very high 1-qubit gate fidelities (0.999+)
 - Moderately high 2-qubit gate fidelities (0.99+)
 - Limited connectivity with good addressability
 - Low-depth sequences of reliable operations
 - Applications limited by gate noise, controllability
- Vendors are offering early access
 - D-Wave, IBM, IonQ, Google, Rigetti
 - Client-server interaction, “cloud” model
 - Very loose integration with modern computing

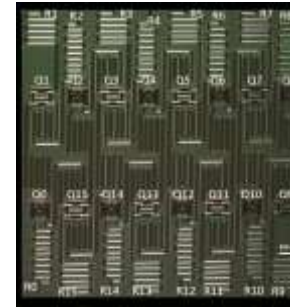

Superconducting chip from IBM



Superconducting chip from Google



Ion trap chip from Sandia

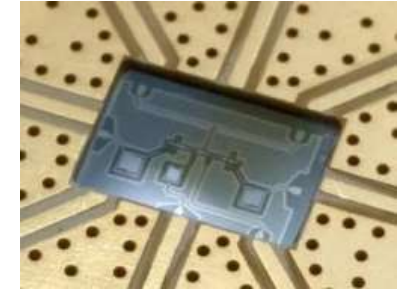

Superconducting chip from Rigetti

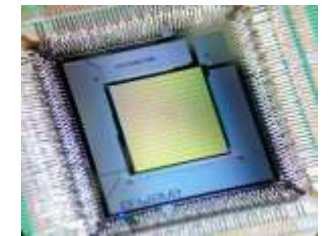

Superconducting chip from D-Wave Systems



Linear optical chip from Univ. Bristol/QET Labs

Executive and Legislative Branches

- National Quantum Initiative
 - Accelerate quantum research for United States' economic and national security
- National Quantum Coordination Office
 - Work with Federal agencies in developing and maintaining quantum programs
- NSTC Subcommittee on QIS
 - Dovetail quantum technology initiatives across the federal government.
- Quantum Economic Development Consortium
 - Expand U.S. leadership in global quantum research and development

White House Summit on QIS

- Office of Science Technology and Policy, SEP '18



NSF/Frances Cordova, DOE/Paul Dabbar,
NIST/Walter Copan, DOD/Mike Griffin

The ORNL vision is to be the international leader in quantum computing for the 21st century.

- Advance quantum computing research from atoms to applications.
- Innovate applications in scientific discovery and energy security.
- Support national priorities with world-class talent and capabilities.
- Impact the public good through strategic partnerships.



IBM

- IBM Q general-purpose system provides 20 qubits
- ORNL is a hub in the IBM Q Network, research evaluation prototype activity



D-Wave

- DW 2000Q special-purpose systems provides 2048 qubits
- Multi-project collaborative research effort focused on application development

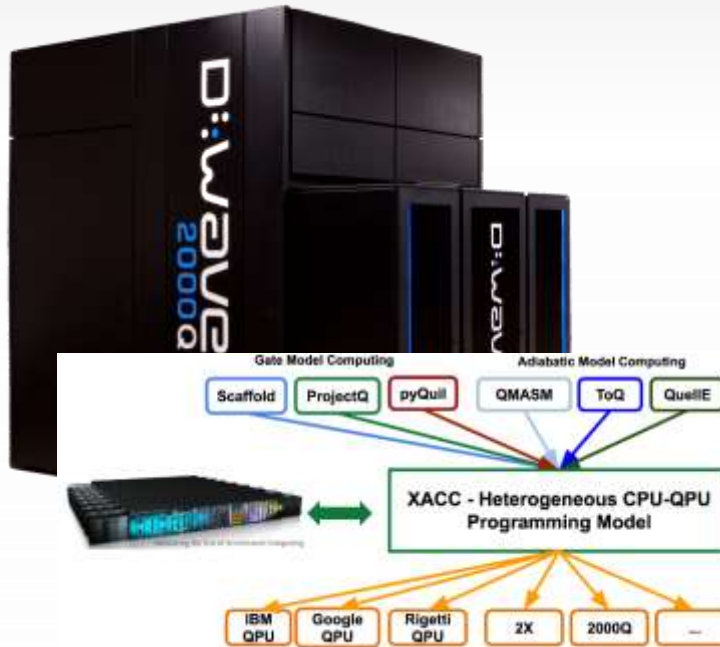
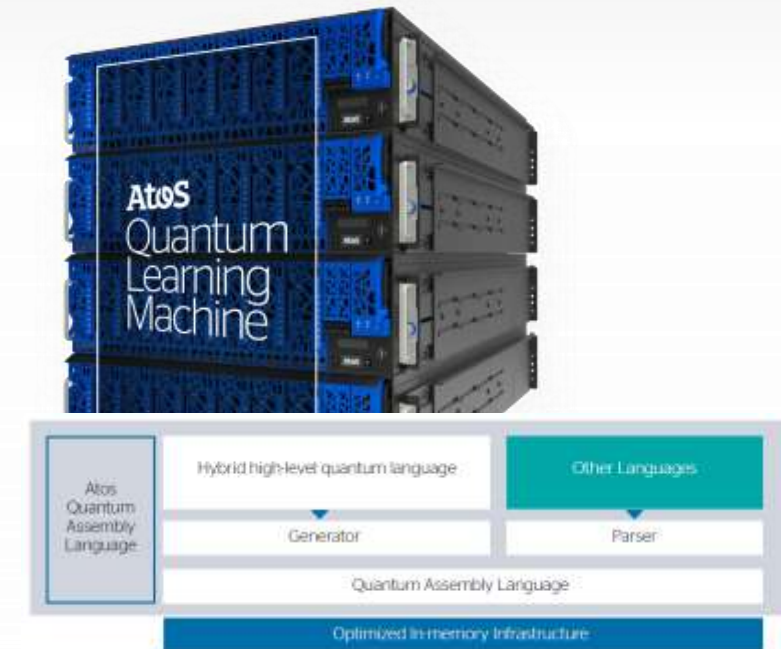

Figure 1. The XACC CPU-QPU programming model enables quantum acceleration in classical HPC applications in a quantum language and hardware agnostic manner.

Atos

- Atos QLM numerical simulators provides 30+ qubit model
- Collaborative research on noise modeling and device validation



Materials

- Transmon qubits encode information in charge states
- Cooper pair electrons coupled by circuit QED resonators

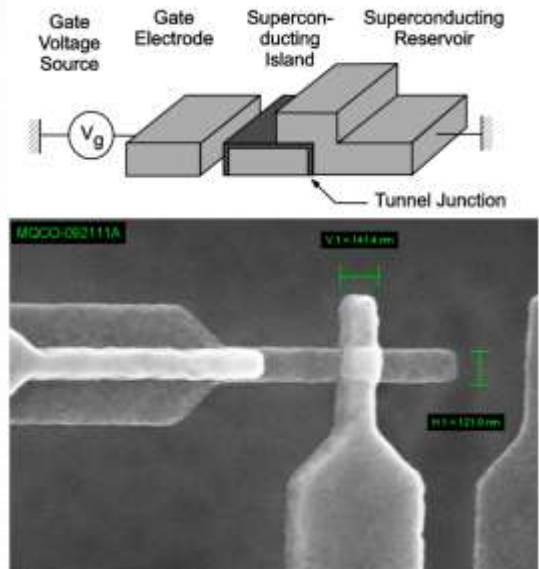

Devices

- Integrated SC circuit with 20-qubit register
- Coherence, $\sim 100 \mu\text{s}$
- Gate pulses $\sim 100 \text{ ns}$
- Gate errors $\sim 1\%$, measure errors $\sim 5\%$

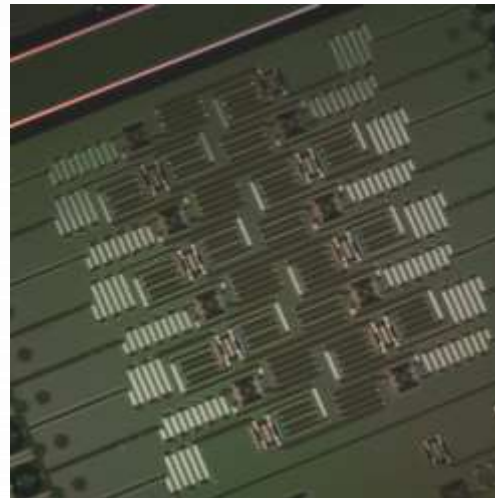

Computing

- Cryogenically cooled to $\sim 13\text{mK}$, isolated
- Signal power $\sim 1 \text{ nW}$



Applications

- Cloud-based access

```
import xacc

# Initialize the framework
xacc.Initialize()

# Get the desired QPU and
# allocate some qubits
qpu = xacc.getAccelerator('ibmq')
qubits = qpu.createBuffer('q',3)

# Define the XACC Kernel
@xacc.qpu(accelerator=qpu)
def teleport(buffer):
    X(0)
    H(1)
    CNOT(1,2)
    CNOT(0,1)
    CNOT(1,2)
    CNOT(2,0)
    Measure(2, 0)

teleport(qubits)

# Display the results
print(qubits)

# Finalize the framework
xacc.Finalize()
```

Benchmarking Quantum Computer Capabilities

Metrics

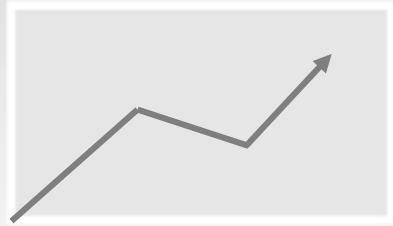

IBM

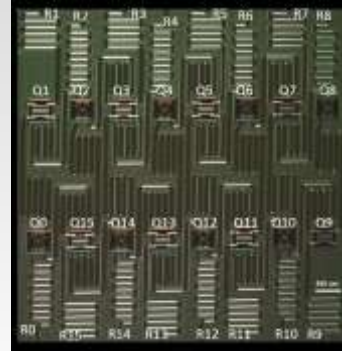

IonQ/UMD

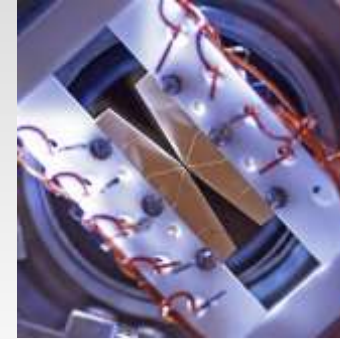

D-Wave

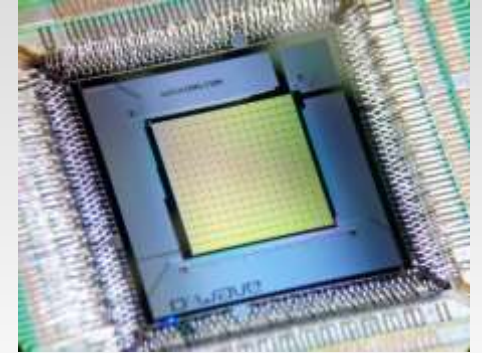

Scale of qubits

5-20

5-11

2048

Initialization fidelity

95%

95%

99.9%

Gate set fidelity

99-95%

99-97%

N/A

Duty cycle

400

2,000

$10^{(-1)}$

Measurement fidelity

95%

95%

99.9%

Swap fidelity

98%

97%

N/A

Transport fidelity

N/A

N/A

N/A

Quantum Computing Use Cases for Scientific Computing

Physical Sciences

- Chemistry, Materials, High-Energy Physics, Nuclear Physics, Fusion

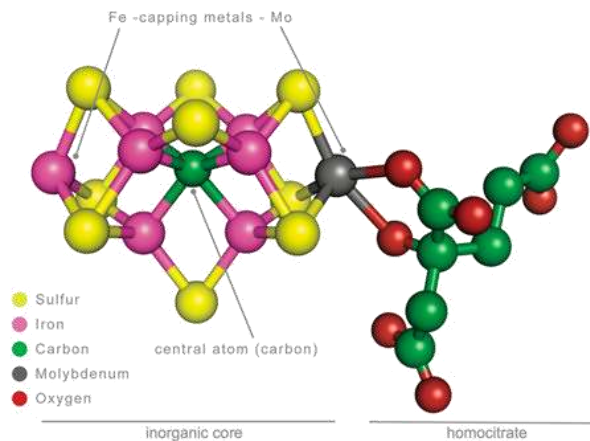

Data Sciences

- Artificial Intelligence, Machine Learning, Inference and Mining

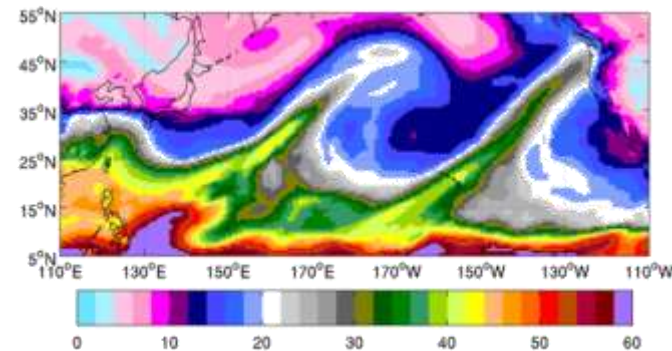

Applied Sciences

- Engineering, Verification and Validation, Energy Sciences

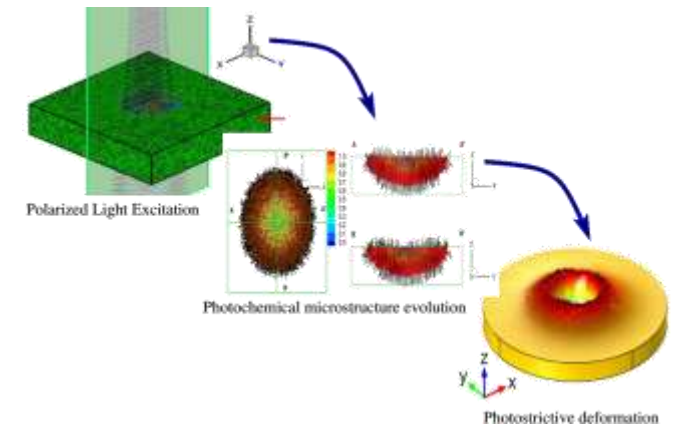

0-3 Years

3-5 Years

+10 Years

Nuclear Physics with Quantum Computing

E. Dumitrescu et al. "Cloud Quantum Computing of an Atomic Nucleus" (2018)

- Nuclear binding energy determines the stability of nuclear isotopes
- Predicting heavy isotope stability is a quantum many-body problem
- We calculate the binding energy of deuteron, the simplest example with a proton-neutron bound state.

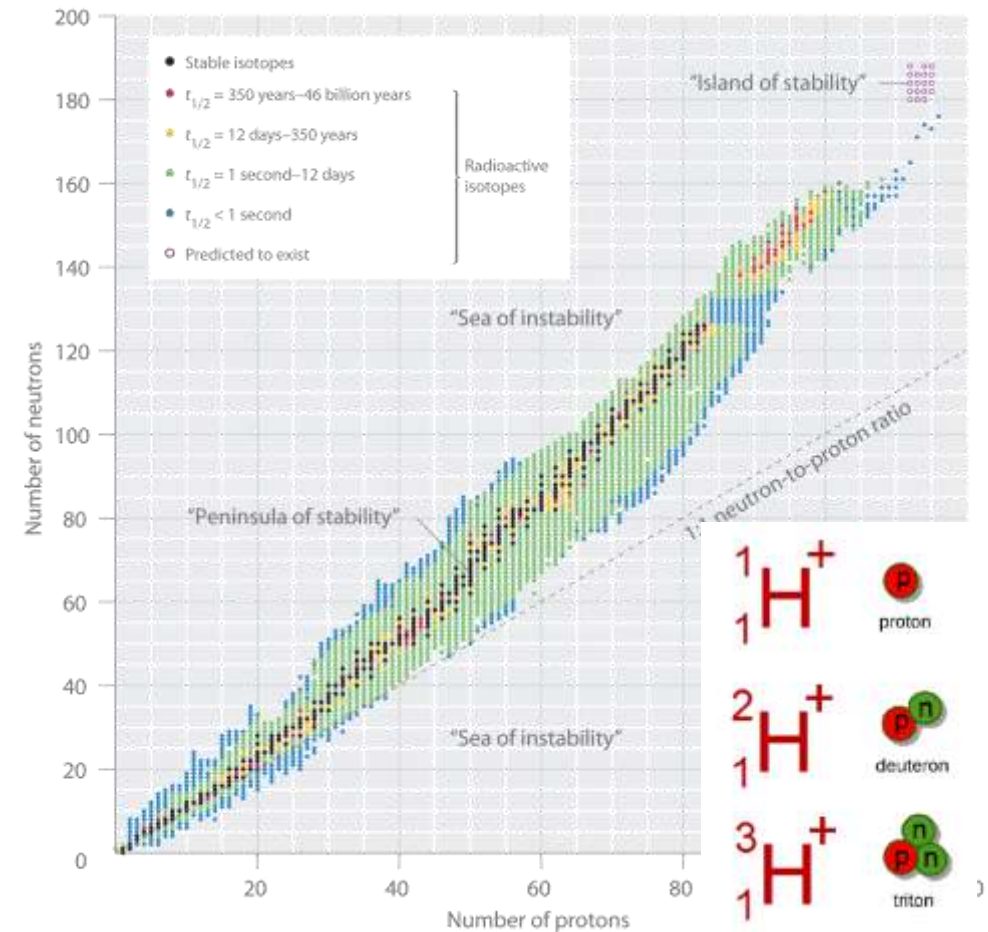

High-energy Physics with Quantum Computing

N. Klco et al. "Quantum-classical computation of Schwinger model dynamics using quantum computers" (2018)

- Quantum chromodynamics is a quantum field theory to describe the strong force
- Calculations of low-energy processes are dominated by symmetry breaking dynamics
- We use a simple lattice QCD model to simulate the dynamics of the quantum fields.

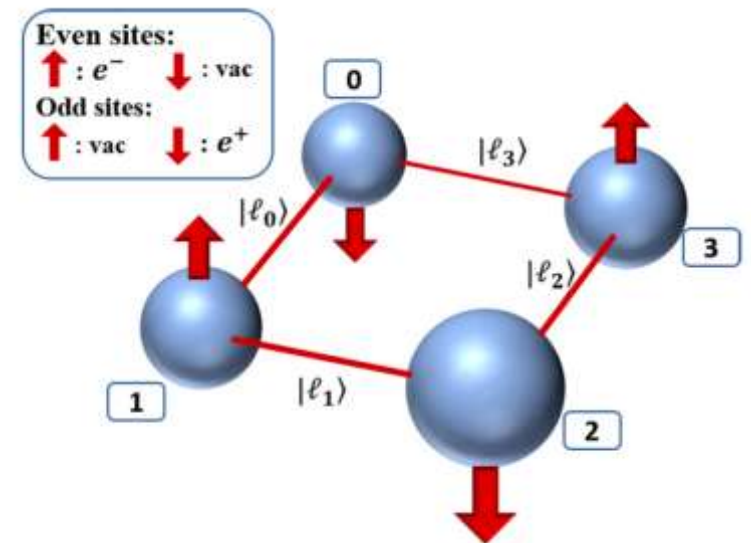
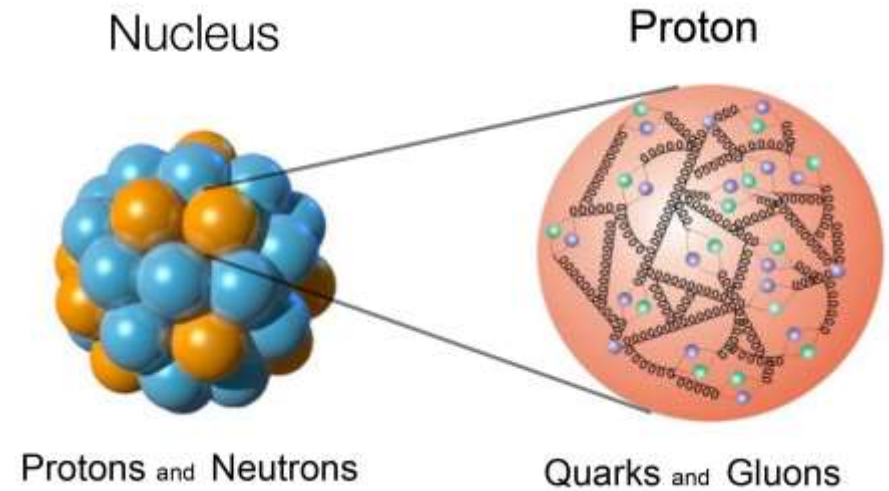

Applied Mathematics with Quantum Computing

C.C. Chang et al. "Quantum annealing for polynomial systems of equations" (2018)

- Solvers for polynomial systems of equations are central to many applications, eg, PDE models
- Convergence often depends on condition number, numerical stability
- We use quantum annealing to show residual error matches conventional solvers but results are independent of condition number

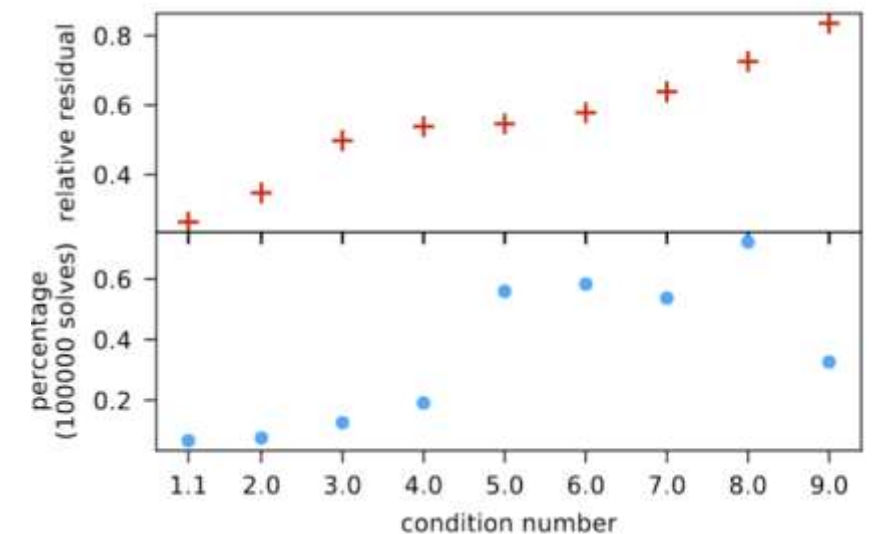
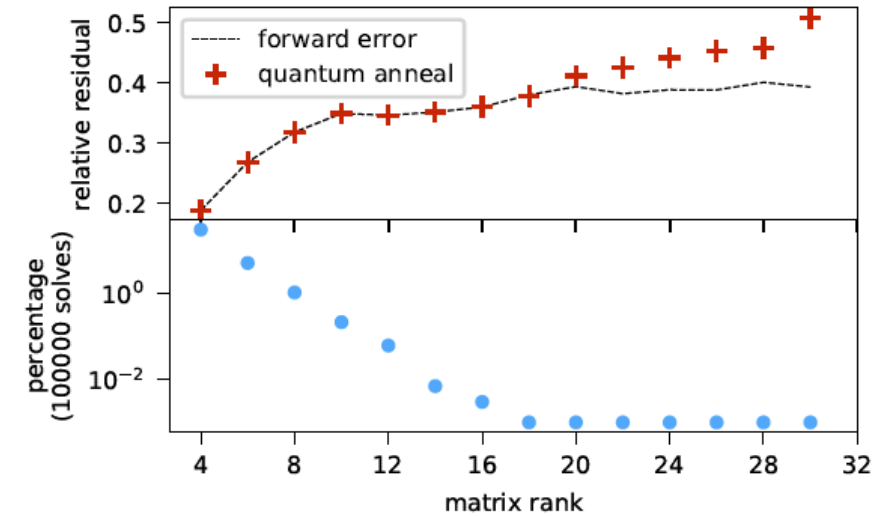

Quantum Accelerated System Architectures

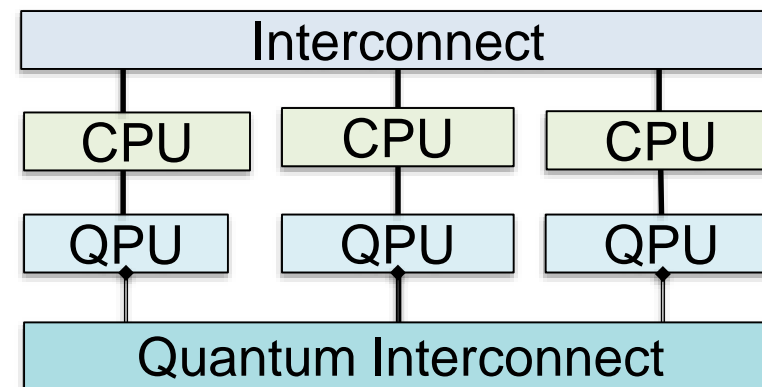
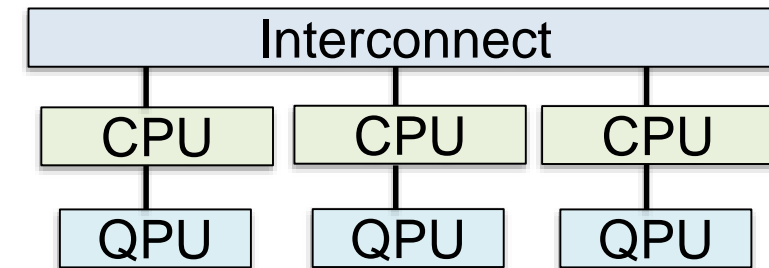
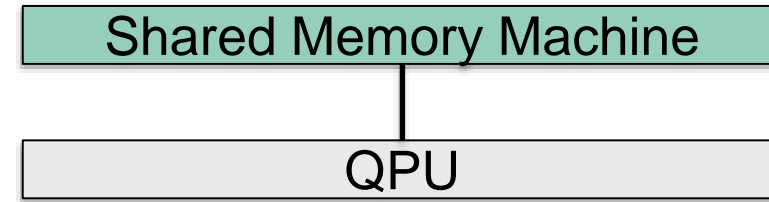
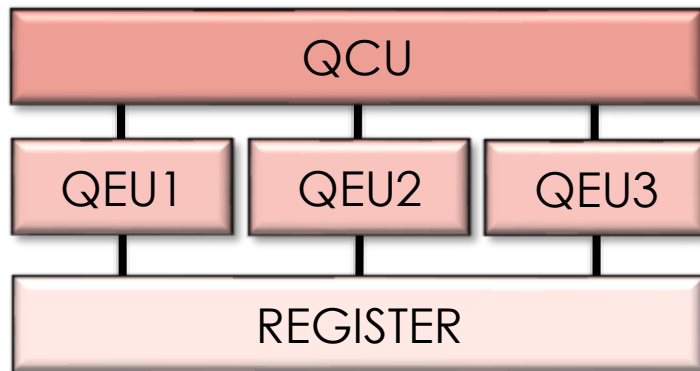
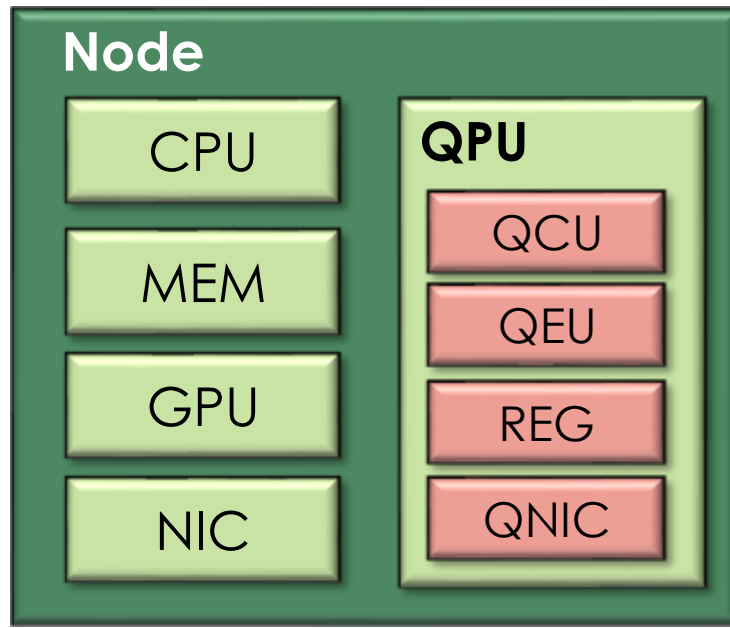

Quantum Accelerated System Architectures

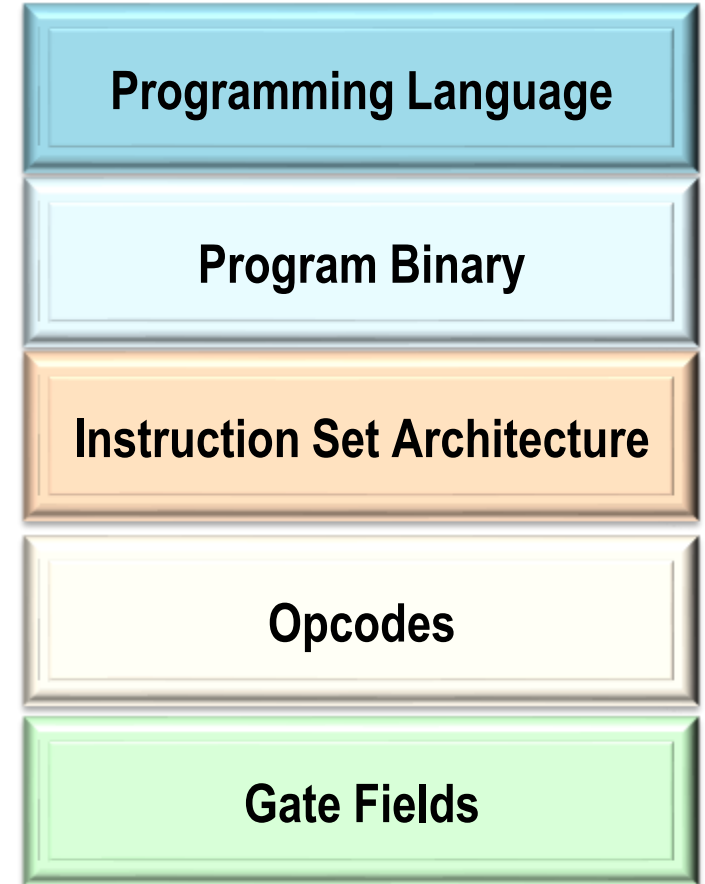
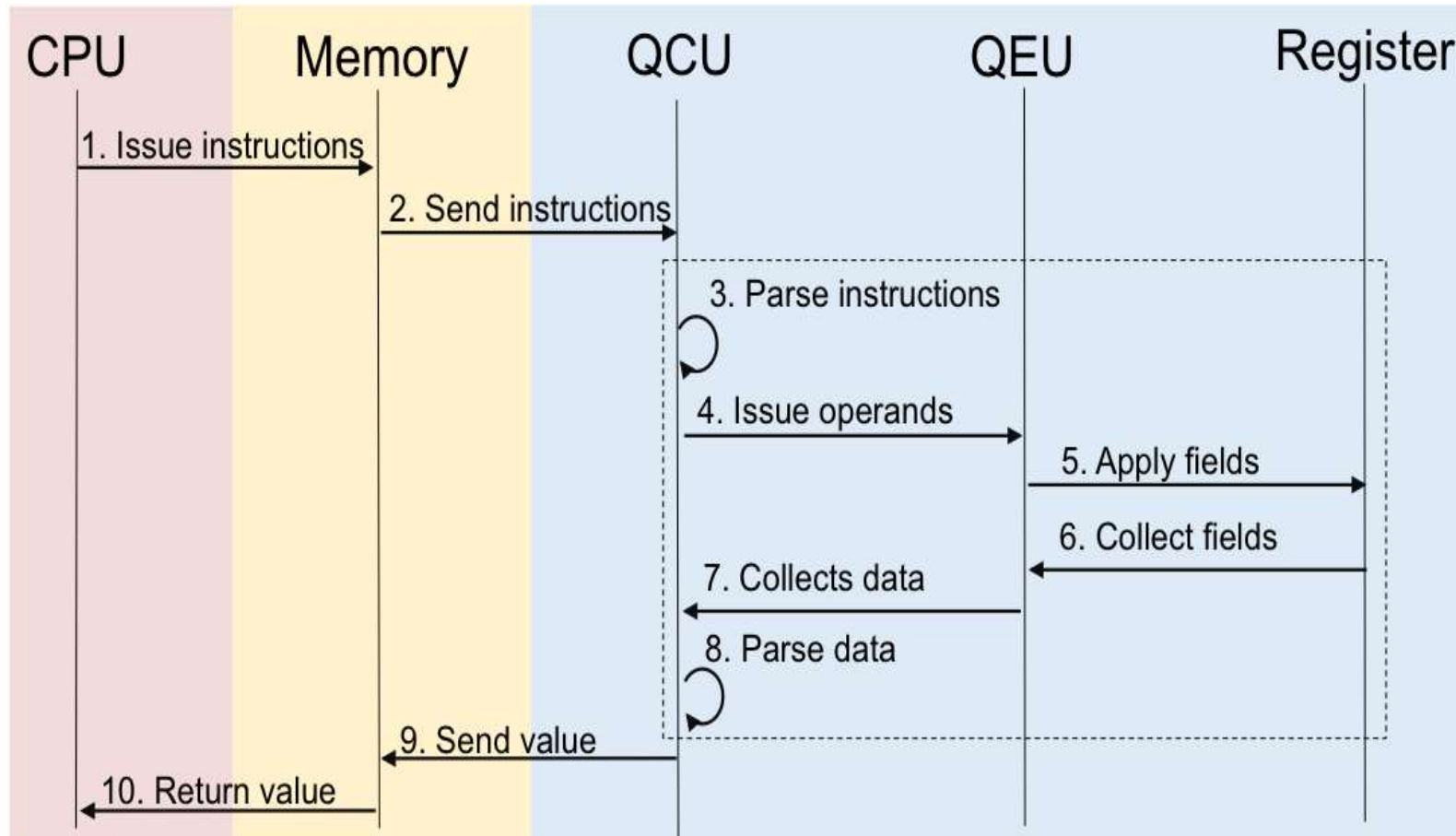

Computer Engineering with Quantum Computing

T. S. Humble et al. "Quantum Acceleration for High-Performance Computing" (2017)

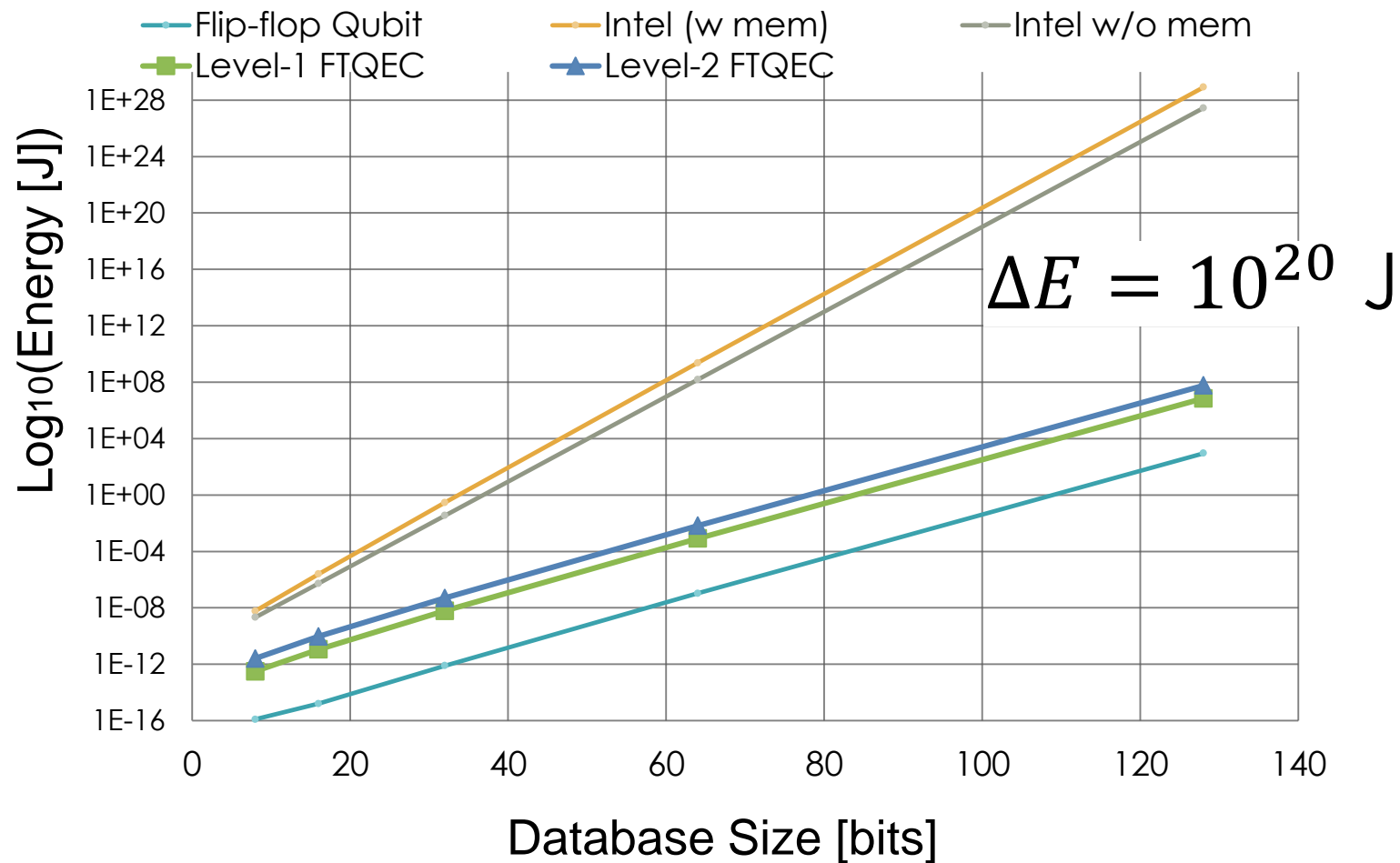
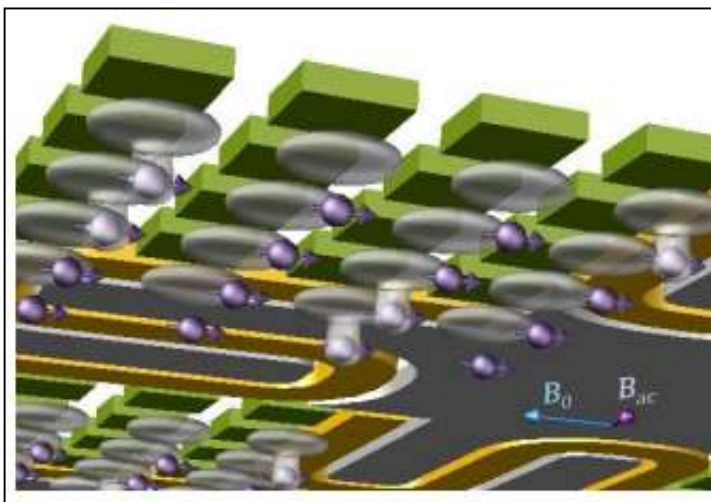

Training

- We are training staff and students to use quantum computers
- We are partnering with universities to provide student research opportunities



Partnerships

- We are partnering with domain scientists to refine quantum algorithms
- We are addressing performance considerations for industrial applications

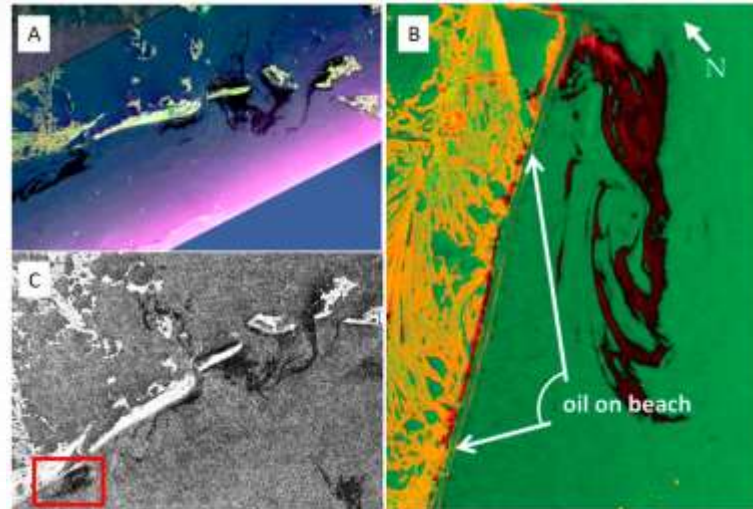

Technology Transfer

- We are partnering with stakeholders to provide early adoption opportunities
- We are leveraging open source for public impact



Quantum Computing User Forum

Brings together users to discuss common practices in the development of applications and software for quantum computing systems.



DATE

Apr 24 2019 - Apr 25 2019



TIME *ET*

08:00 AM - 05:00 PM



LOCATION

Building 8600, Room A103
Oak Ridge National Laboratory, Oak Ridge,
TN 37831

www.olcf.ornl.gov/calendar/quantum-computing-user-forum

Software Working Group

- With Eclipse Foundation
- A user community to develop use cases, requirements, and application profiling across system stacks.



Developers
Programmers
Engineers
Vendors

<https://code.ornl.gov/QCSWG>

Benchmarking Group

- New IEEE Quantum Initiative
- A community to define and evaluate metrics for quantum processors



Vendors
End-Users
International
Engineers

<http://quantum.ieee.org/>

QCI Newsletter

- Weekly email newsletter, 500+
- Review the latest news, press, due dates, jobs and events
- Email quantum@ornl.gov to join the distribution list
- Share news and events



Stakeholders
Scientists
Engineers
Vendors

quantum@ornl.gov

Quantum Computing

- Computing with quantum mechanics
- Information encoded in superposition and entanglement
- Synthesize, fabricate and control arrays of high quality materials

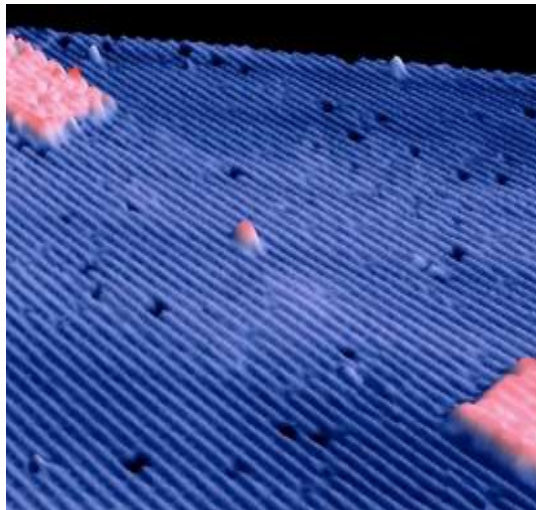

High Impact

- New methods for scientific discovery
- A technology path after exascale?
- National and energy security applications

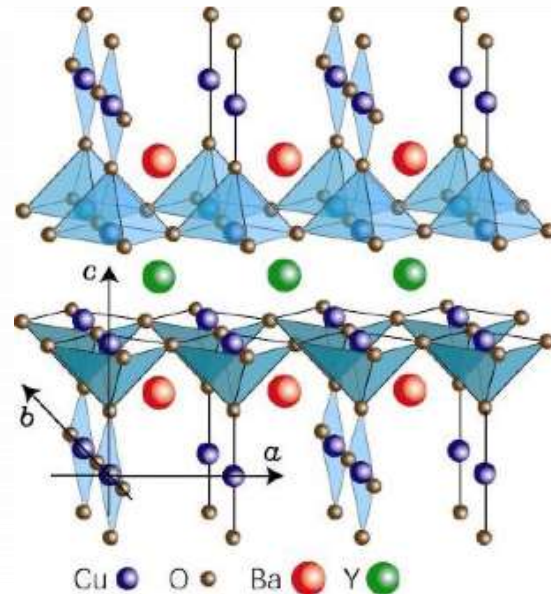

Today's Science

- Programmable physics experiments
- Exploratory research
- Emerging market of quantum technology



Tomorrow's Tech

- Driven by economics, engineering, science
- Plan for integration, adoption, and workforce

