

Progress on superconducting multi-qubits system

Xiaobo Zhu

CAS Center for Excellence in Quantum Information and Quantum Physics

University of Science and Technology of China



Superconducting QC groups in China



IOP-China, Tsinghua university,
and Beijing Computational Science
Research Center

Nanjing university

Zhejiang university

USTC-Shanghai

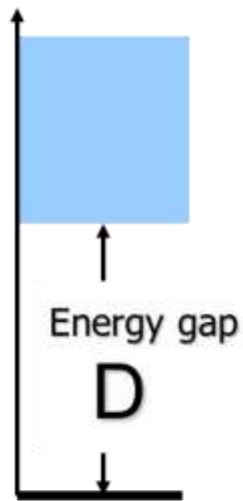

Superconductor
 $T \ll T_c$

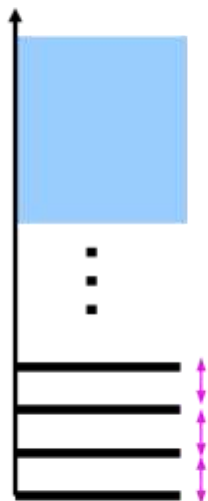
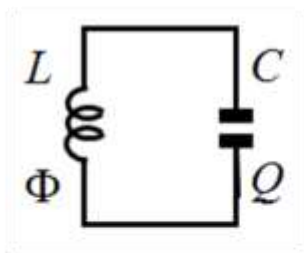

Harmonic oscillator

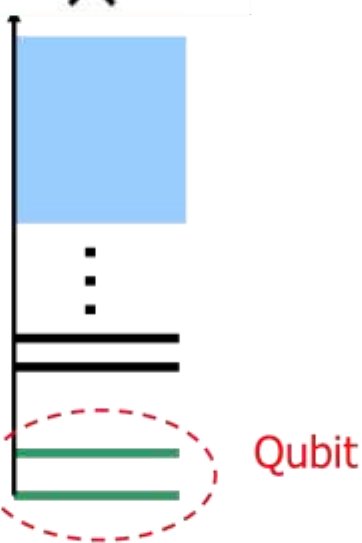
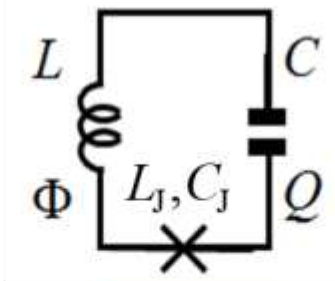

Josephson Junction

Josephson Junction



PN Junction

Basic element of superconducting quantum processor

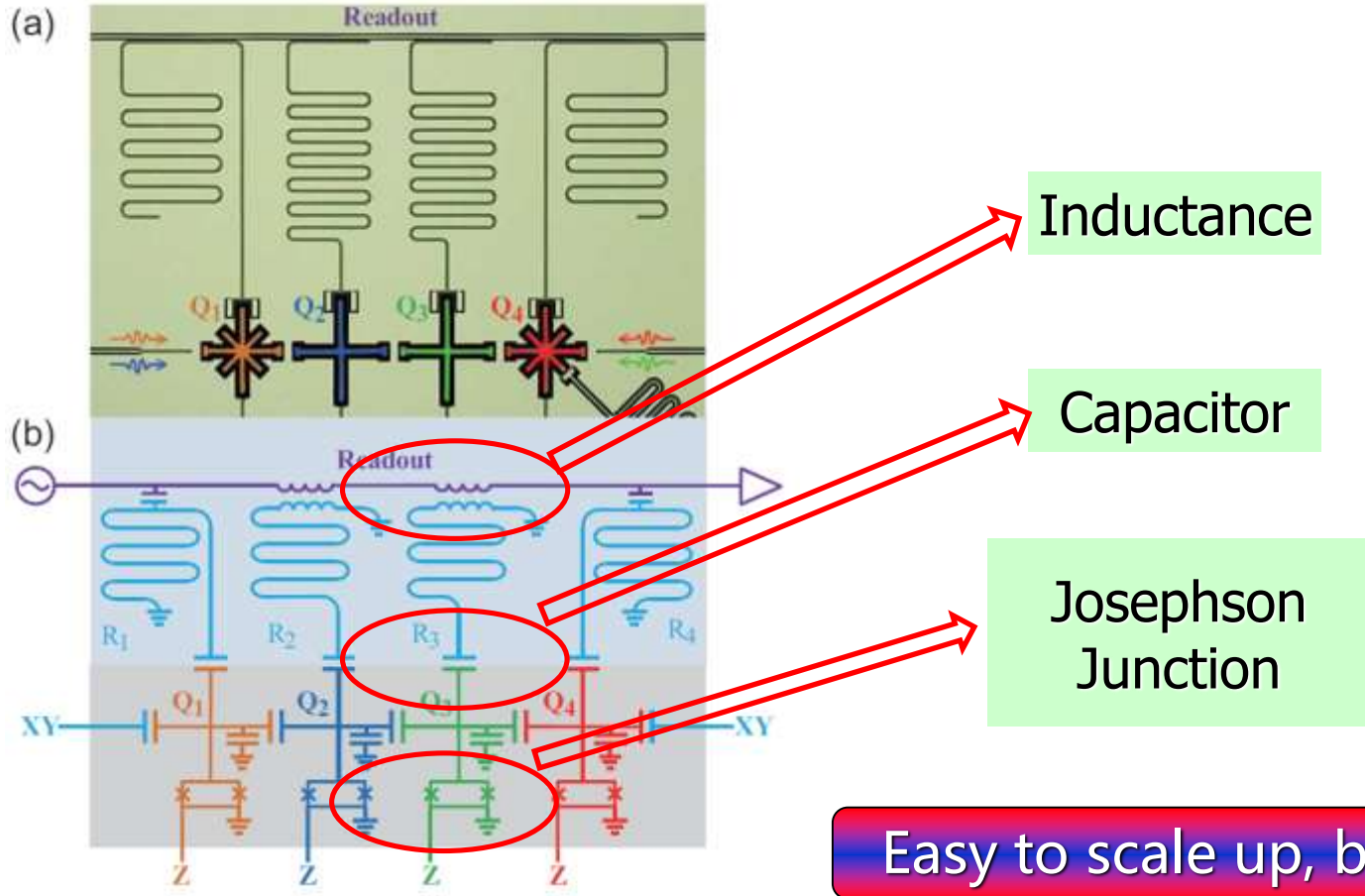

Qubit characterizations

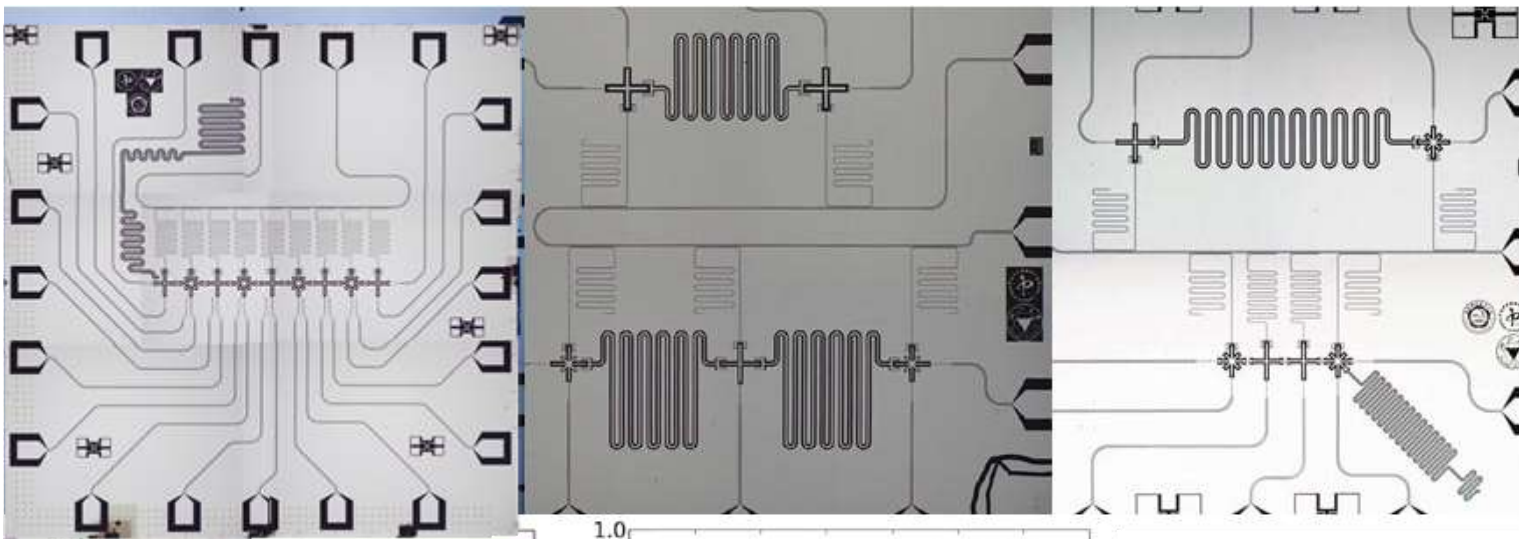

5 qubits
6 qubits
9 qubits
10 qubits
20 qubits
...

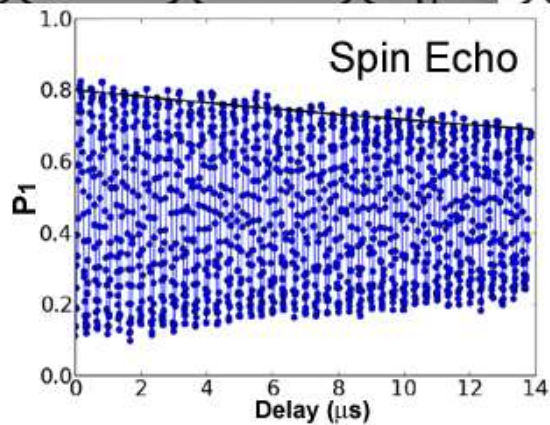
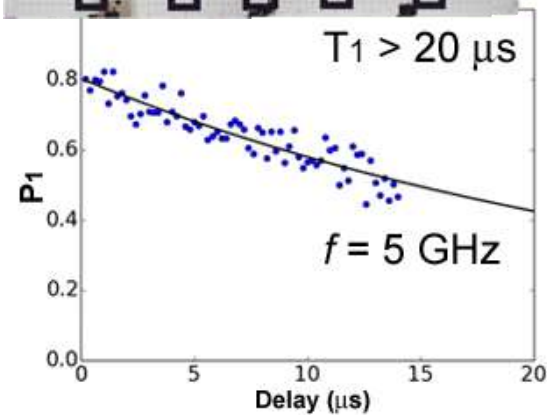

✓ **Transmon/Xmon qubits:**

Best $T_1 \sim 30 \mu\text{s}$ (10 – 20 μs on average), T_2^* above 20 μs (- 10 μs on average).

✓ **Single-qubit gate fidelity above 99.9% (RB), two-bits gate $\sim 99.1\%$**

Readout with home-made paramps

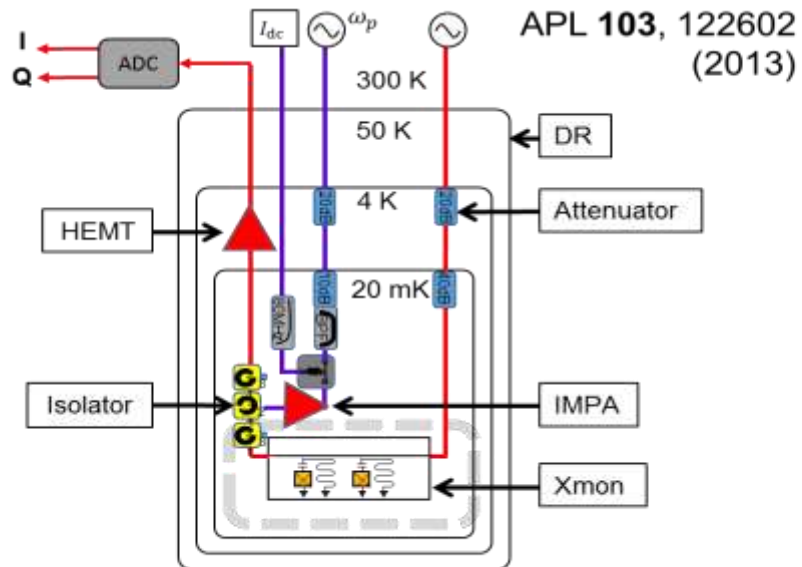

- Single-shot readout in less than $1\mu\text{s}$

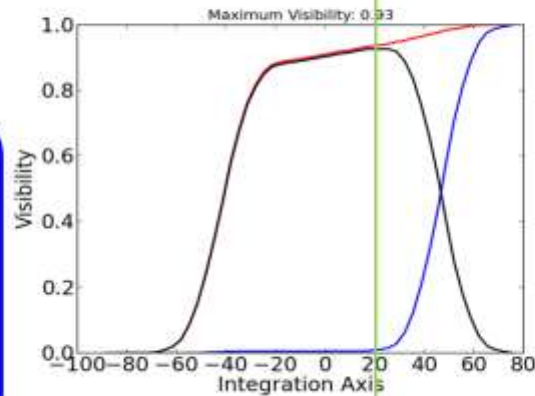
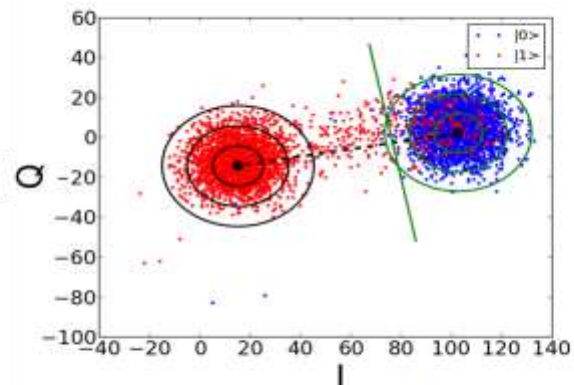

APL 104, 263513 (2014)

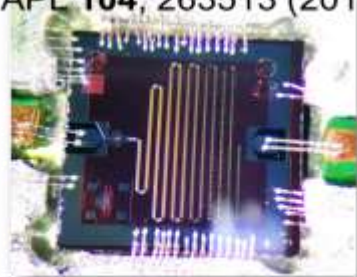

- Good for 6 qubits

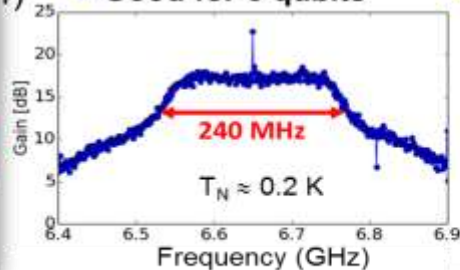

10-Qubit Entanglement with a Superconducting Circuit

10-Qubits processor with complete connection

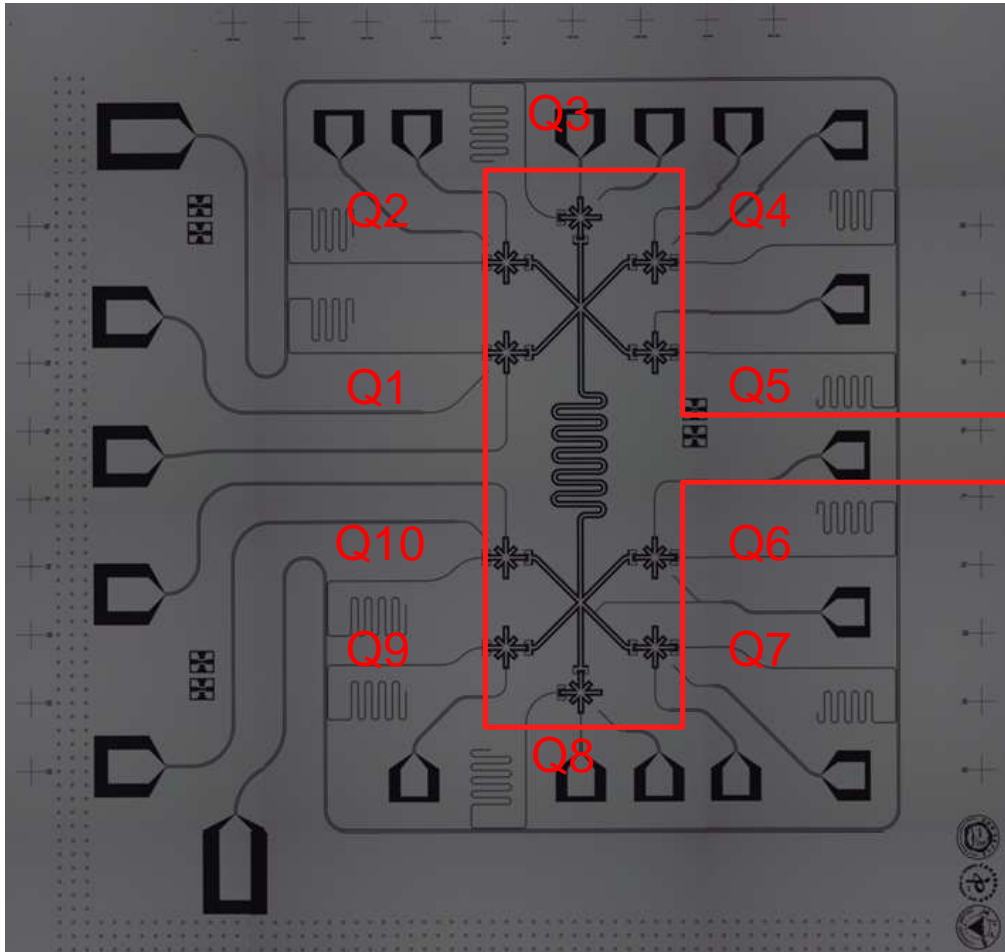

Center
Resonantor

List of parameters

	Q_1	Q_2	Q_3	Q_4	Q_5	Q_6	Q_7	Q_8	Q_9	Q_{10}
$\omega_j^0/2\pi$ (GHz)	5.782	5.831	5.828	5.780	5.760	5.863	5.780	6.004	5.893	5.930
$\omega_I/2\pi$ (GHz)					≈ 5.655	$\omega_B/2\pi \approx 5.795$				
$T_{1,j}$ (μs)	27.2	24.4	10.9	15.0	19.2	23.7	13.8	11.8	17.1	22.0
$T_{2,j}^*$ (μs)	2.9	2.8	2.8	2.2	2.6	1.8	1.1	2.1	1.7	4.4
$T_{2,j}^{\text{SE}}$ (μs)	11.8	10.6	10.0	10.8	11.7	8.9	8.0	8.0	7.9	11.8
$\omega_j/2\pi$ (GHz)	5.080	5.467	5.657	5.042	5.179	5.605	4.960	5.260	5.146	5.560
$g_j/2\pi$ (MHz)	14.2	20.5	19.9	20.2	15.2	19.9	19.6	18.9	19.8	16.3
X/2 fidelity	0.9985(2)	0.9992(1)	0.9984(1)	0.9987(2)	0.9991(1)	0.9964(5)	0.9987(1)	0.9980(3)	0.9988(3)	0.9989(1)
Simultaneous X/2 fidelity	0.9978(7)	0.9980(2)	0.9953(5)	0.9955(5)	0.9985(2)	0.9962(3)	–	–	0.9979(2)	0.9931(12)
$\omega_j^r/2\pi$ (GHz)	6.509	6.541	6.615	6.614	6.635	6.694	6.691	6.794	6.809	6.891
$g_j^r/2\pi$ (MHz)	41.3	39.9	40.6	38.2	38.5	40.4	41.8	40.9	40.2	38.7
$\delta\omega_j^m/2\pi$ (MHz)	31.1	32.7	21.1	46.5	9.0	45.1	22.5	19.5	26.0	70.2
n_j^r	92	59	31	180	30	81	93	74	103	203
$1/\kappa_j^r$ (ns)	291	275	272	348	223	284	248	266	299	242
$F_{0,j}$	0.921	0.955	0.982	0.974	0.962	0.988	0.950	0.970	0.961	0.971
$F_{1,j}$	0.867	0.915	0.904	0.928	0.927	0.917	0.922	0.880	0.894	0.934

GHZ state preparation

$$H/\hbar = \omega_B a^\dagger a + \sum_{j=1}^{10} [\omega_j |1_j\rangle\langle 1_j| + g_j (\sigma_j^+ a + \sigma_j^- a^\dagger)]$$

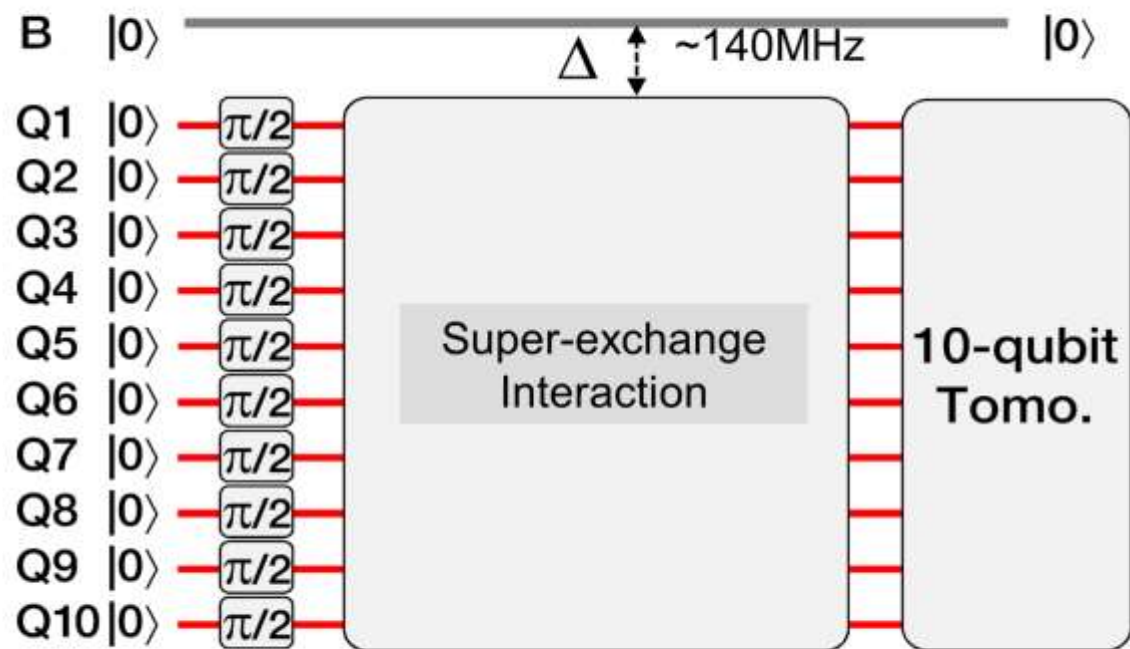

$$|\Psi_1\rangle = (|+1, +2, \dots, +N\rangle + e^{i\varphi} |-1, -2, \dots, -N\rangle) / \sqrt{2},$$

Full state tomography

GHZ state fidelity
is about 66%

PRL 119, 180511 (2017)

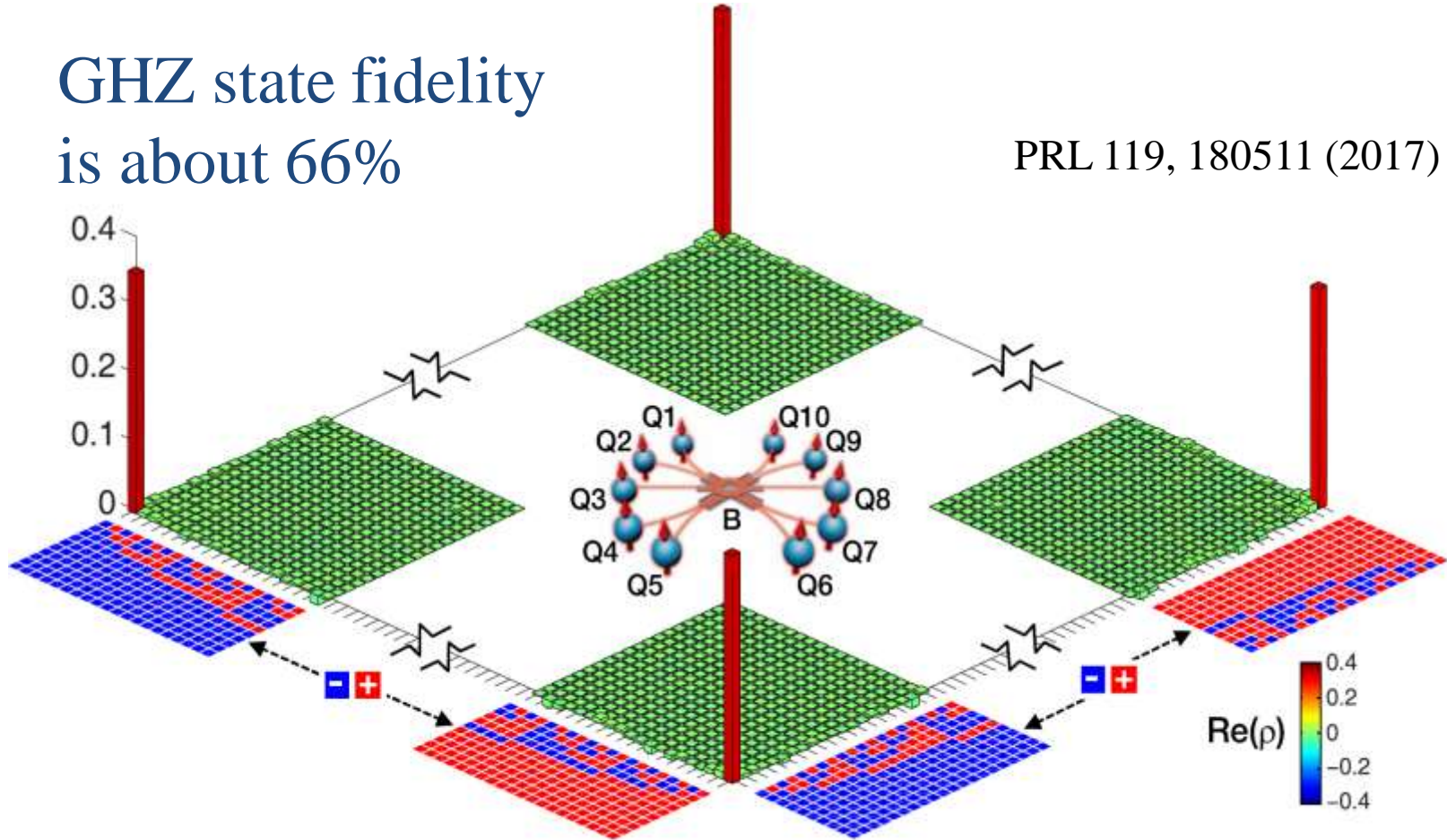

4 bits HHL algorithm

$$\mathbf{A} \vec{x} = \vec{b} \quad \text{where } \mathbf{A} \text{ is Hermitian.}$$

?

- ✓ To describe the $N \times N$ Hermitian matrix A ,
the computational basis of $\log_2(N)$ qubits is needed.

- ◆ λ_j is the j^{th} eigenvalue of A , and \vec{u}_j is the eigenvector.
with $\vec{b} = \sum_j \beta_j \vec{u}_j$, the solution is

$$\vec{x} = \sum_j \frac{\beta_j}{\lambda_j} \vec{u}_j$$

4 qubits HHL algorithm

In the frequency range for this work:

$$T_1 \sim 10\text{-}15 \mu\text{s}$$
$$T_2^* \sim 3\text{-}5 \mu\text{s}$$

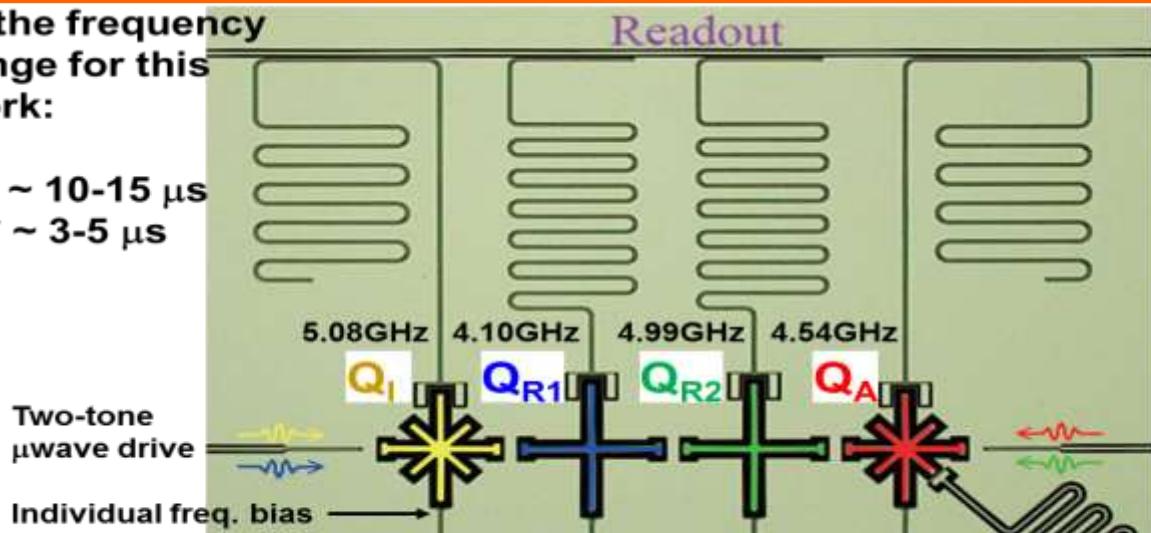

Photo Courtesy: Yarui Zheng

$$A = \begin{pmatrix} 1.5 & 0.5 \\ 0.5 & 1.5 \end{pmatrix}$$

Phys. Rev. Lett. **110**, 230501 (2013)
Phys. Rev. A **89**, 022313 (2014)
Scientific Reports **4**, 115 (2014)

No solid-state demonstration so far.

Input qubit

1 input qubit

to encode
a 2-component vector.

Register qubits

2 register qubits for

$|01\rangle$, $|10\rangle$, or $|11\rangle$,

$\lambda_j = 1, 2, \text{ or } 3.$

Ancilla qubit

No constraint

Immediate goal with these 4 qubits: to solve 2×2 linear eqns.

4 qubits HHL algorithm

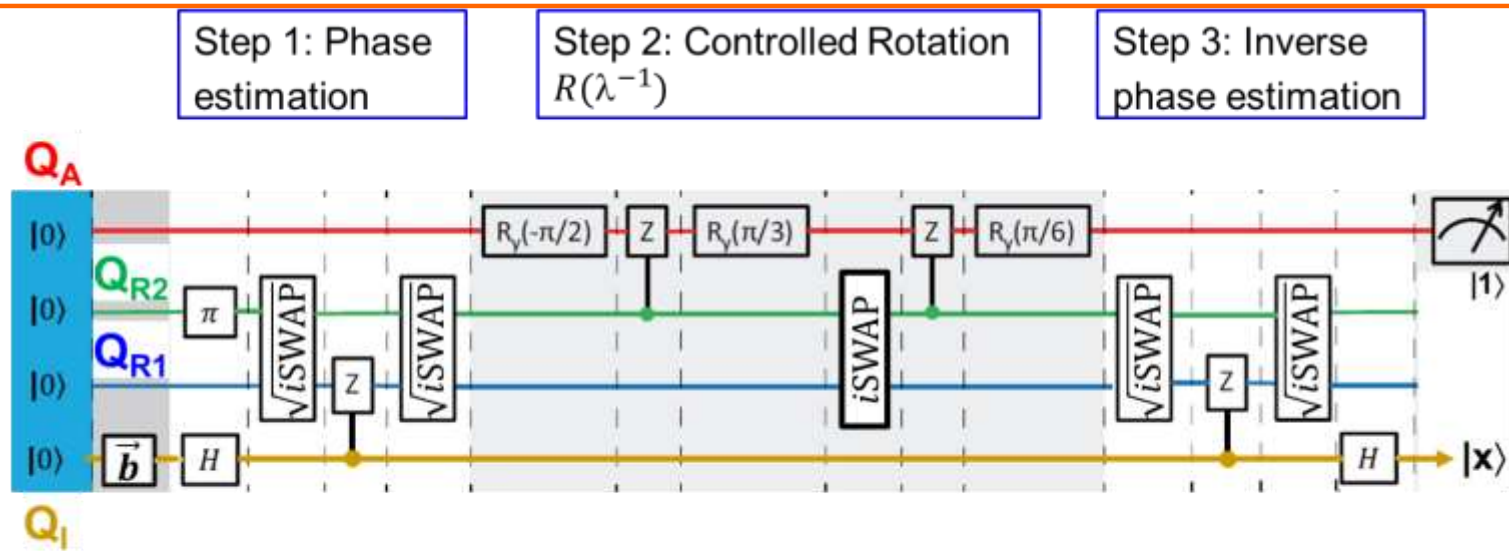

- ✓ As done previously, the “Controlled- U ” gate needed for phase estimation is pre-calculated from \mathbf{A} and compiled into the circuit.
- ✓ The sequence consists of **9 single-qubit gates and 9 entangling gates**.
- ✓ During idling adjacent two qubits are far detuned (interaction off).
- ✓ Entangling gates are done by tuning qubit frequencies.

4 qubits HHL algorithm

Input for \vec{b} Exp. state tomography of \vec{x}

$$\begin{pmatrix} 1 & 0 \\ 0 & 0 \end{pmatrix} \quad \begin{pmatrix} 0.82 & -0.17 - 0.03i \\ -0.17 + 0.03i & 0.18 \end{pmatrix}$$

ideal \vec{x}

$$\begin{pmatrix} 0.9 & -0.3 \\ -0.3 & 0.1 \end{pmatrix}$$

Input state	Fidelity
$ 0\rangle$	0.859
$ 1\rangle$	0.874
$\cos(\pi/8) 0\rangle - i\sin(\pi/8) 1\rangle$	0.861
$\cos(\pi/4) 0\rangle - i\sin(\pi/4) 1\rangle$	0.886
$\cos(3\pi/8) 0\rangle - i\sin(3\pi/8) 1\rangle$	0.881
$\cos(\pi/8) 0\rangle + i\sin(\pi/8) 1\rangle$	0.881
$\cos(\pi/4) 0\rangle + i\sin(\pi/4) 1\rangle$	0.856
$\cos(3\pi/8) 0\rangle + i\sin(3\pi/8) 1\rangle$	0.840
$\cos(\pi/4) 0\rangle + e^{-i\frac{\pi}{4}}\sin(\pi/4) 1\rangle$	0.890
$\cos(\pi/4) 0\rangle + e^{i\frac{\pi}{4}}\sin(\pi/4) 1\rangle$	0.872
$\cos(\pi/4) 0\rangle + e^{-i\frac{3\pi}{4}}\sin(\pi/4) 1\rangle$	0.884
$\cos(\pi/4) 0\rangle + e^{-i\frac{3\pi}{4}}\sin(\pi/4) 1\rangle$	0.882

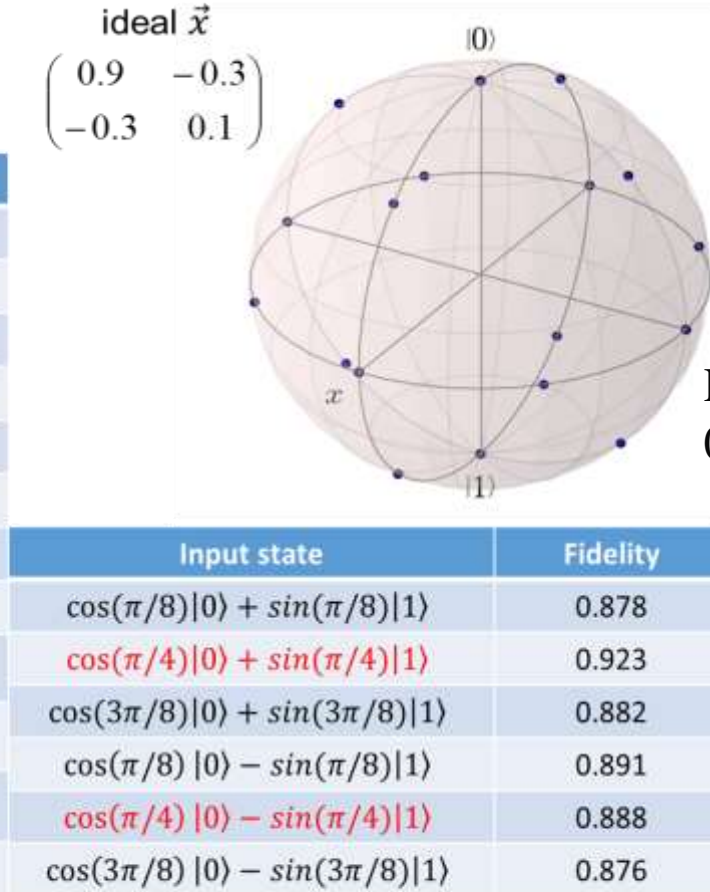

PRL 118.2105
04 (2017)

High Fidelity Gate

Single Qubit Gates

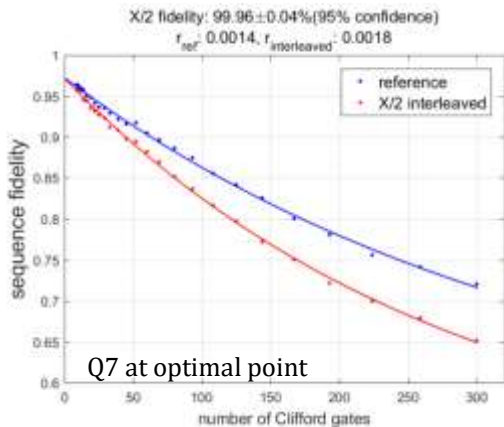

Q7 at optimal point

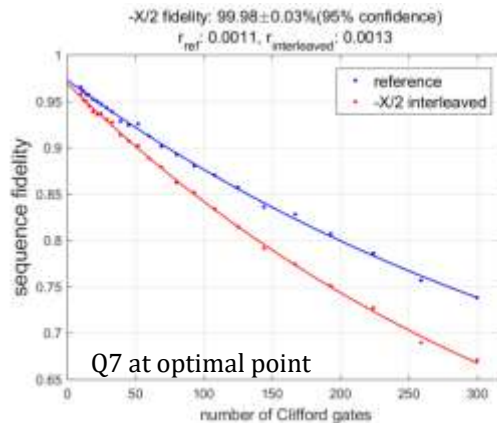

Q7 at optimal point

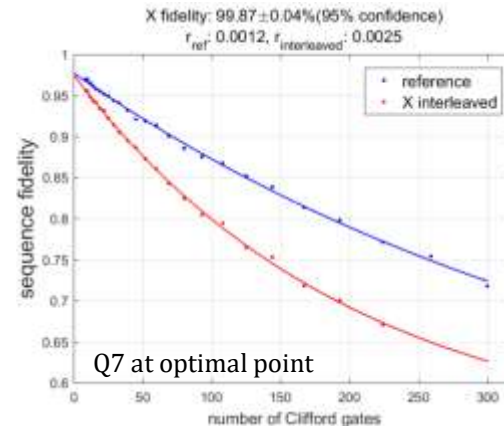

Q7 at optimal point

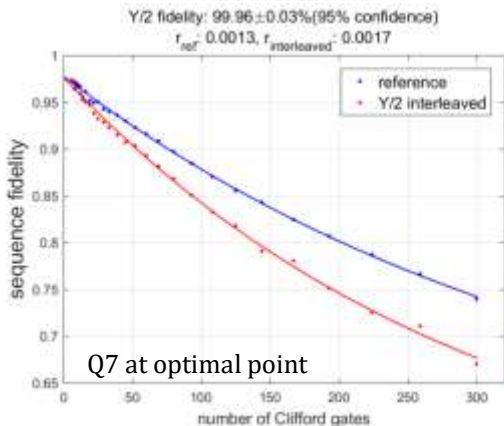

Q7 at optimal point

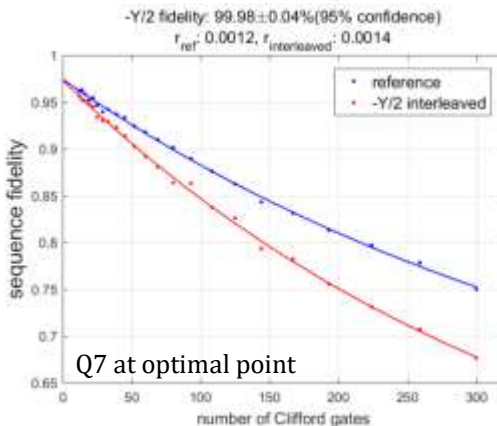

Q7 at optimal point

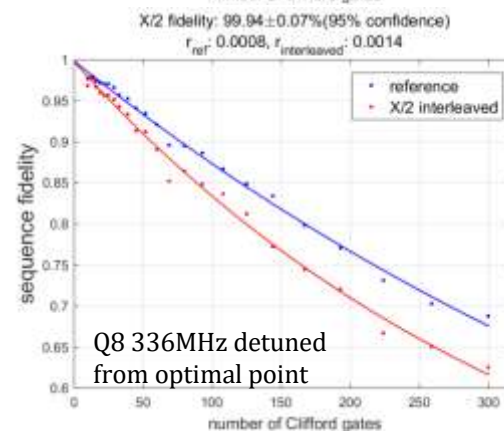

Q8 336MHz detuned
from optimal point

Single qubit gate randomized benchmarking $> 99.9\%$

CZ Gate

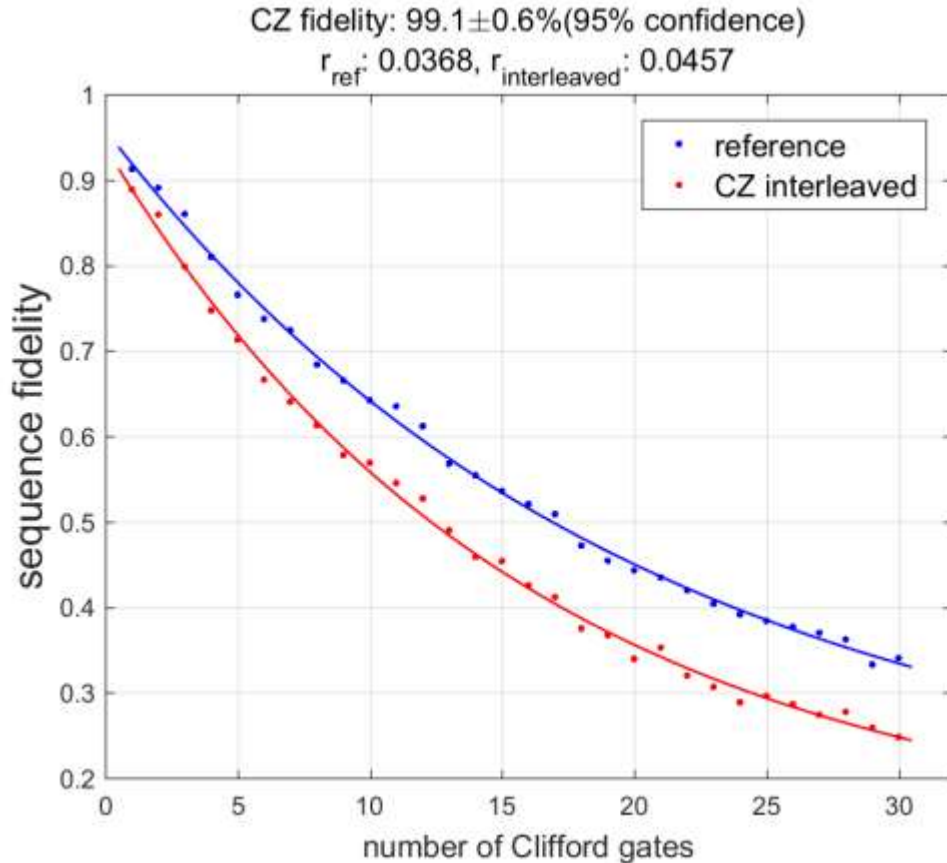

CZ randomized
Benchmarking
70 random sequences
1500 averages

Quantum Computing Cloud Accessed

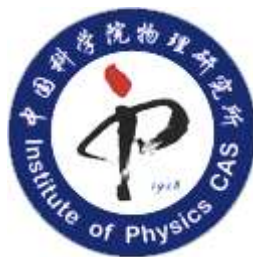

Introduction to Quantum Computing Cloud Accessed



- Cloud accessing is future of QC
- Help us to know how good and stable we can
- Stimulate interest in QC

The Structure of QC Cloud System

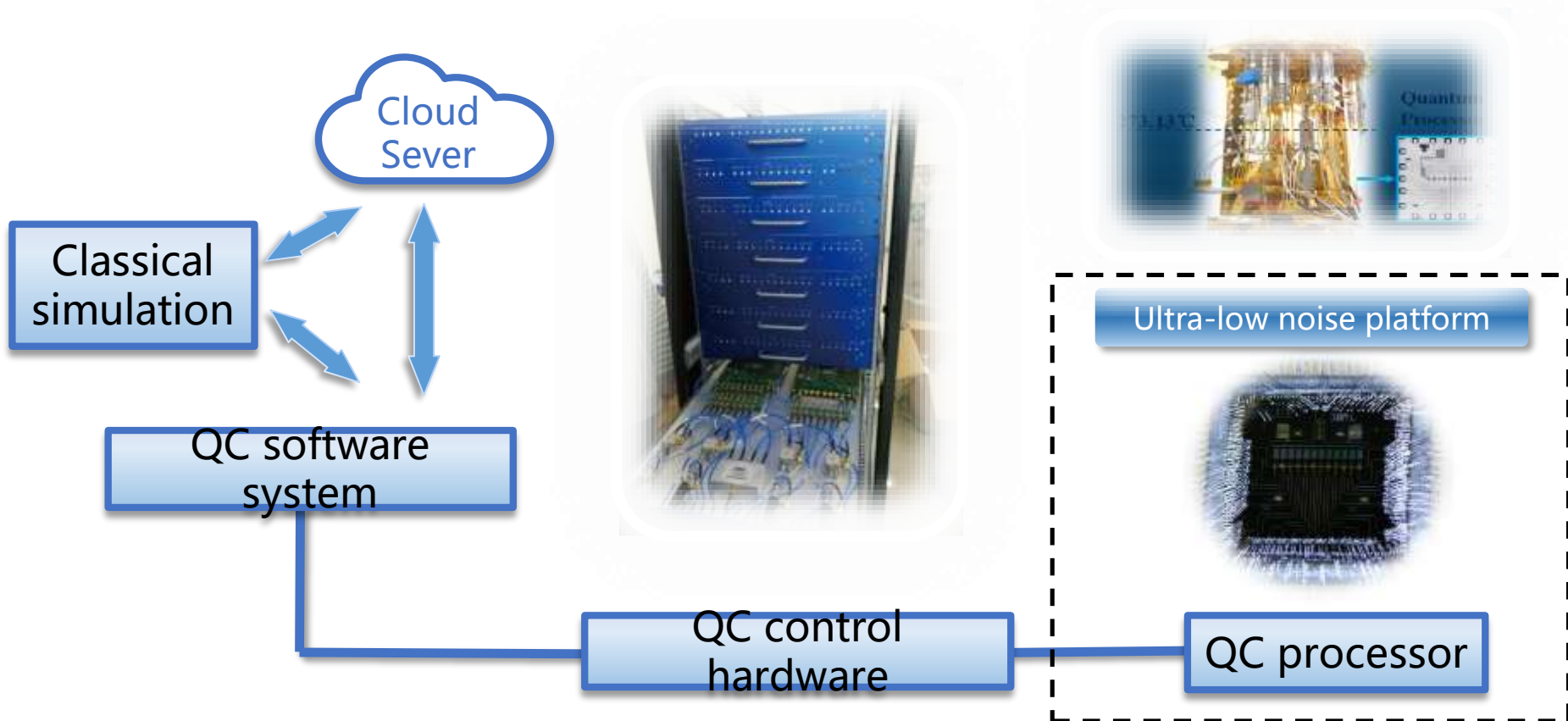

QC Processor

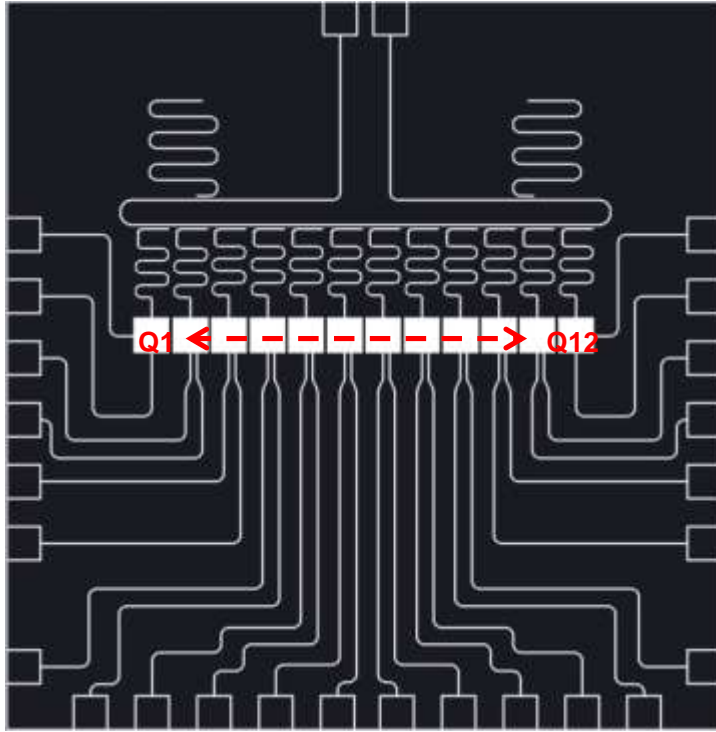

- 12 bits, 11 of them are opened
- 1D ring connection
- Single bit: 99.7% (RB)
- Two bit : 94.9% (Tomo)

How to use it

How to use it

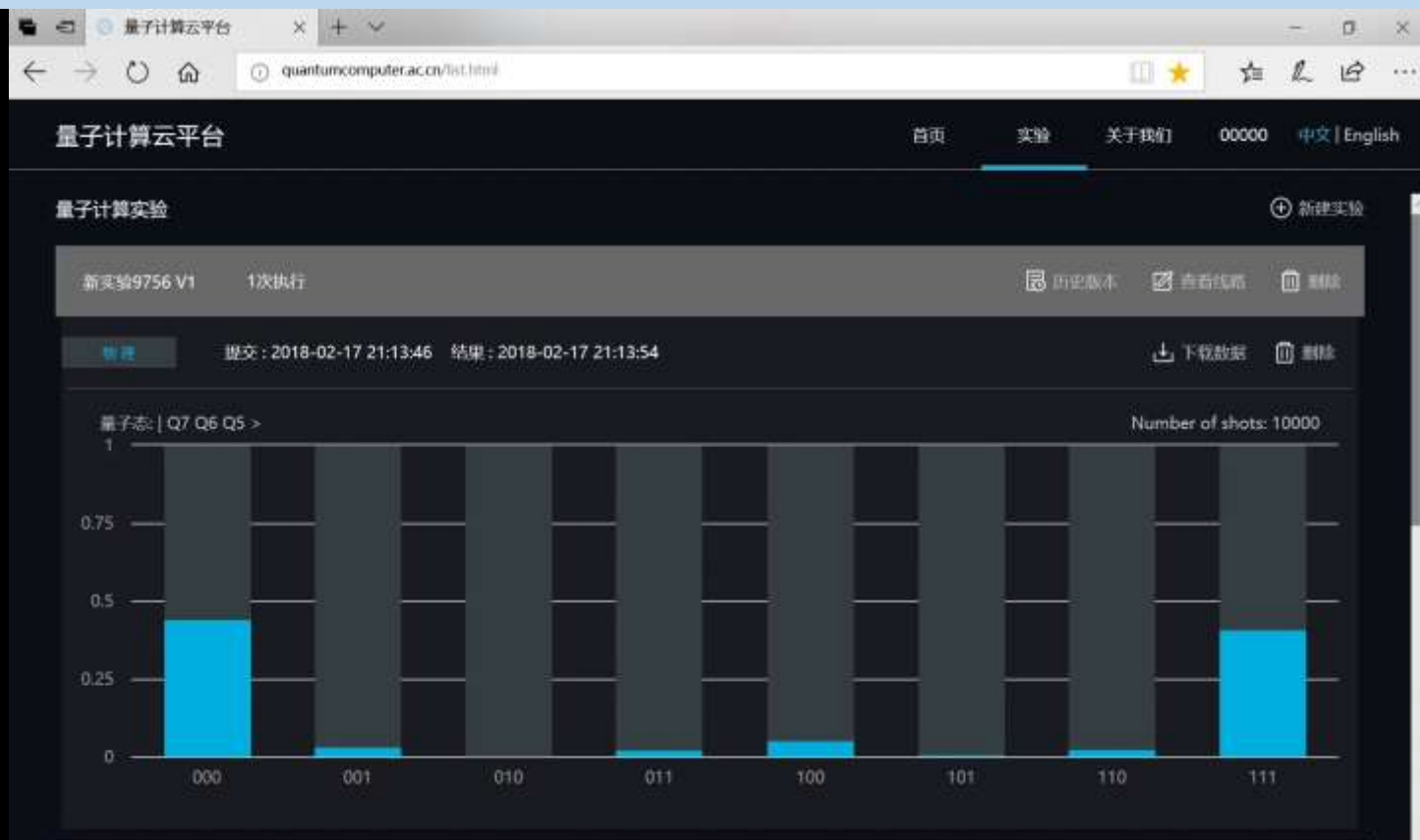

The results returned

Summary

- We designed and fabricated several versions of quantum processor, on which integrated up to 20 qubits
- The typical T_1 and T_2 time are both longer than 20 microseconds
- The single-bit gate fidelity is $>99.9\%$ and for the CZ gate it reaches 99.1% in the best case
- We use a four-qubit processor to solve a two-dimensional system of linear equations, yield a process fidelity of 0.837 ± 0.006
- We generate a 10-bit GHZ state with a fidelity of 0.668 ± 0.025
- 11-bit quantum processor is online now quantumcomputer.ac.cn

Thank you for your attention!